



RUGGEDIZED STATUS INDICATORS

COMMERCIAL | MILITARY

Event Counter / Hour Meter
ETIs



Filtered / NVIS
LEDs

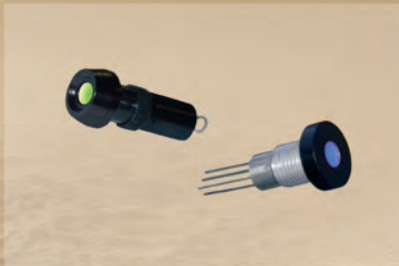

Flag / Ball / Drum Display
Indicators

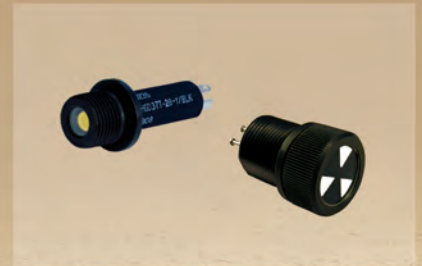

L-3 ELECTRODYNAMICS, INC.

STATUS INDICATORS

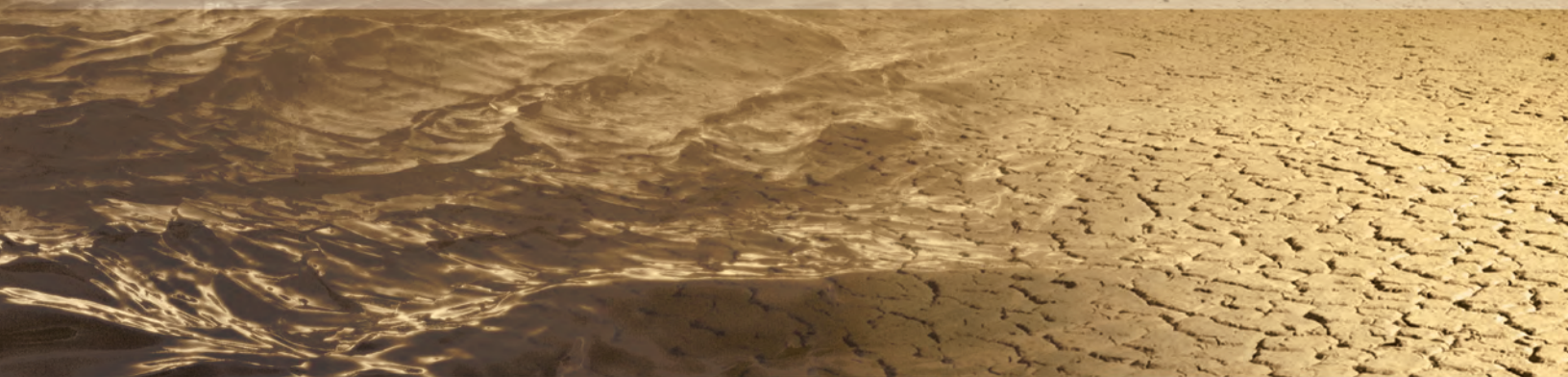



Solid-state indicators provide system information

FEATURES

- Environmentally sealed
- Rugged packaging
- Pinpoint or wide-angle viewing area
- EMI shielding available
- Anti-reflective coating optional
- Panel mount & rear mount designs
- Models available to meet NVIS and MIL-Spec requirements
- Custom designs



FIGURE 1



FIGURE 2



FIGURE 3



FIGURE 4



FIGURE 5



FIGURE 6



FIGURE 7



FIGURE 8



FIGURE 9



FIGURE 10



FIGURE 11



FIGURE 12



FIGURE 13



FIGURE 14



FIGURE 15

Fig. No.	Models	Environ Sealed	Panel Seal	Rear Mount	Panel Mount	Internal Resistors	Wide Operating Voltage	Night Vision	Infrared Secure	High Brightness	EMI Shielded	Tri-Color Bi-Color LED	Page No.
1	ML1600 ^②	•			•	•							32
2	ML1610	•	•		•								32
3	ML1618 ^④	•			•				•				34
4	ML1619 ^{④⑨}	•			•				•		•		36
5	MLD1619 ^{④⑤}	•			•				•		•		38
6/7	ML1620/ML1630 ^②	•	•		•	•					•		40
6/7	ML1620-S/ML1630-S	•	•		•						•		42
6/7	ML1622/ML1632 ^②	•	•		•	•					•	B	44
8/7	ML1623-S/ML1633-S ^{①②}	•	•		•	•					•	B	46
9	ML1631 ^⑧	•	•	•							•	T	48
10	ML1634	•	•	•							•	B	50
11	ML1635 ^①	•	•	•							•	B	52
10	ML1636 ^②	•	•	•		•					•		54
10	ML1636-U	•	•	•						•	•		56
10	ML1638 ^③	•	•	•				•			•		58
11	ML1638 Bi-Color ^{①③}	•	•	•				•			•	B	60
12	ML1640 ^⑦	•	•		•						•		62
4	ML1662 ^③	•	•		•			•			•		64
13	ML2030E ^⑥	•	•		•						•		66
14	ML2031 ^⑧	•	•		•						•	T	68
13	ML2038E ^③	•	•		•			•			•		70
15	ML4036	•	•	•			•			•	•		72

Notes: ^① 3-Leaded ^② Internal Resistors for 5VDC to 28VDC usage. ^③ MIL-L-85762A ^④ CECOM Secure Lighting ^⑤ Dimmable Filter feature ^⑥ DESC Drawing 85122 ^⑦ DESC Drawing 87019 ^⑧ 4-Leaded ^⑨ DESC Drawing 87019

This page consists of basic marketing information that is not defined as technical data under EAR Part 772.

MINIATURE LED INDICATOR



Models ML1600 & ML1610

Designed for use as function indicators on aircraft, test equipment, machine tools and wherever severe environmental conditions need to be met.

FEATURES

- Performs in severe environments
- Low power use
- Long life
- High efficiency
- High visibility
- Rugged construction
- Readily mounted on panel

MECHANICAL SPECIFICATIONS

Case: Black anodized aluminum
Mounting: Front panel by 5/16"-32 nut and lockwasher
Weight: 1.5 grams with hardware
Seal: Environmentally sealed. Added front panel O-ring seal for model ML1610.



ENVIRONMENTAL SPECIFICATIONS

Vibration: .06" D.A. or 20 Gs Peak, whichever is less, 10Hz to 2kHz, MIL STD 202, Method 204, Test Condition D
Shock: 100 Gs MIL STD 202, Method 213, Test Condition I
Moisture Resistance (Humidity): MIL STD 202, Method 106
Barometric Pressure (Reduced): 100,000 ft., MIL STD 202, Method 105, Test Condition D
Reliability: 3 x 10⁶ hours min. MTBF @ 25°C
Salt Atmosphere (Corrosion): MIL STD 202, Method 101, Test Condition B

ELECTRO-OPTICAL CHARACTERISTIC SPECIFICATIONS*

Absolute Maximum Ratings @Temp = 25°C			
Color	Red	Yellow	Green
Forward Voltage (VDC) typical @ 20 mA	1.9	2.0	2.1
Peak Forward Current (mA) ①	90	60	90
Max DC Forward Current (mA) ②	30	20	30
Reverse Voltage (VDC) @ I _R = 100 µA	5	5	5
Power Dissipation (mW)	135	85	135
Luminous Intensity (mcd) typical @ I _F = 10 mA	Non-diffused	50	70
	Diffused	7.0	8.0
Luminous Intensity (mcd) typical @ I _F = 10 mA	Non-diffused	22	14.7
	Diffused	5.4	5.7
Dominant Wave Length (nm) typical	626	585	569
Viewing Angle (2 Ø ^{1/2}) typical	Non-diffused	35°	24°
	Diffused	60°	60°
Operating Temperature (°C)	-55 to +100	-55 to +100	-20 to +100
Storage Temperature (°C)	-55 to +100	-55 to +100	-55 to +100
Lead Soldering Temperature	260°C for 5 seconds		

Notes: ① Typical pulsing values: t_p ≤ 10 µsec, Duty cycle = 10%
 ② For red and green, derate linearly from 50°C @ 0.5 mA/°C. For yellow, derate linearly from 50°C @ 0.2 mA/°C

*These characteristics reflect the baseline model. Variations may imply a difference in luminous characteristics and/or operability features. Please contact the EDI Sales Department for more information.

This page consists of basic marketing information that is not defined as technical data under EAR Part 772.

MINIATURE LED INDICATOR



ORDERING INFORMATION

When ordering, show basic part number first, followed by the color of the LED, lens type, and terminal style. If this is a special part, a factory assigned modification number will be added at the end of the ordering number. Consult the factory for special configurations.

Example:

A basic model with an O-ring panel seal, a yellow LED, a diffused lens, and loop terminals would be ML1610-Y-D-LT.

ML1610 - Y - D - LT - () - ()

Standard factory options are designated by "-Sxxx"

Basic Model Number	LED Color	Lens Type	Terminal Style	Internal Resistor
ML1600 (w/o O-ring)	R Red	ND Non-diffused	ST Straight Terminals	() No Resistor
ML1610 (with O-ring)	Y Yellow	D Diffused	LT Loop Terminals	5 5V
	G Green			24 24V

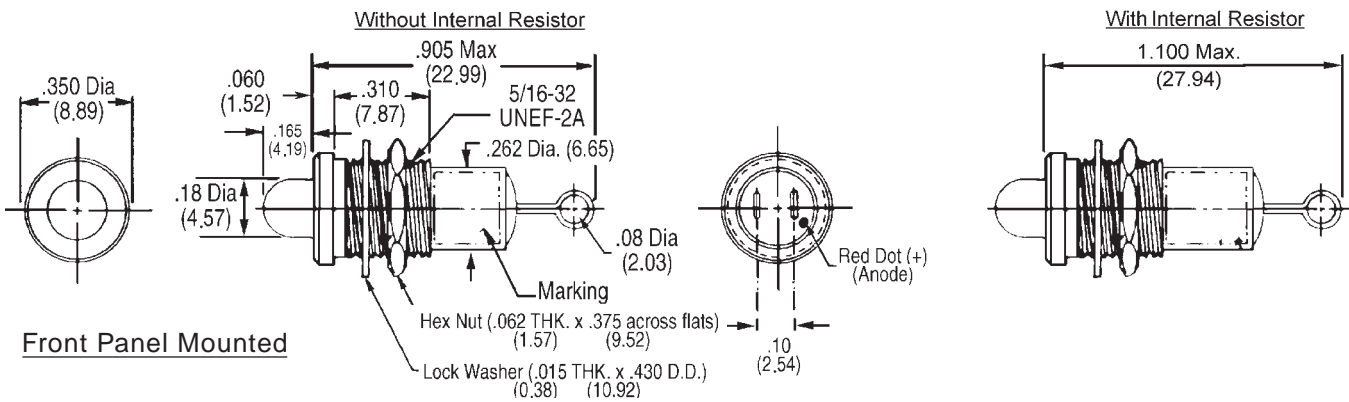

ML1600
Environmentally sealed – no O-ring

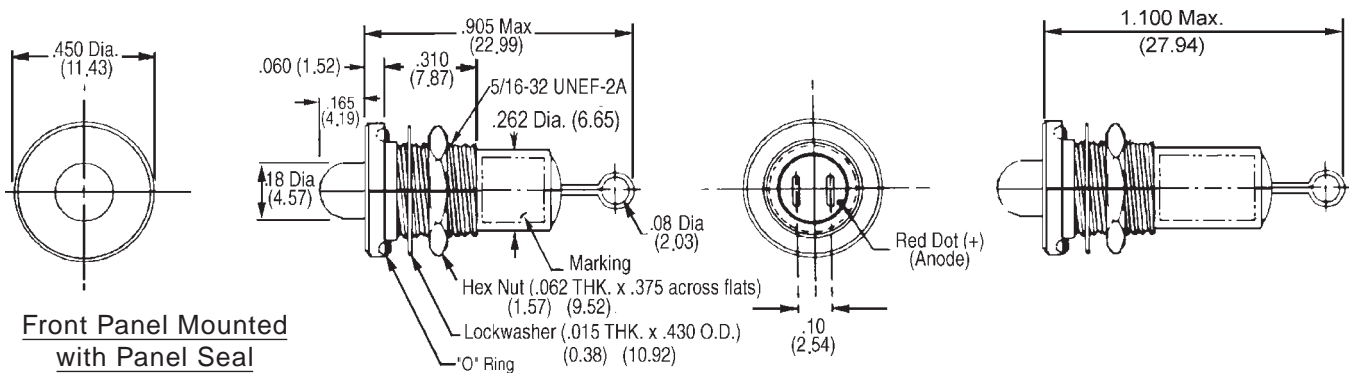

Front Panel Mounted
with Panel Seal



Recommended
Mounting Hole

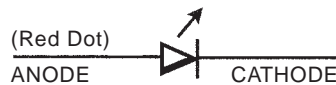

Schematic

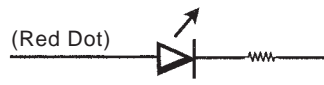

Schematic
with Internal Resistor

ML1610
Environmentally sealed – with front panel O-ring

NOTE: Dimensions in () are mm. Tolerances: Decimals: ± .010 (0.25)
Fractions: ± 1/64 Mounting Torque: 5-7 in. lbs.

This page consists of basic marketing information that is not defined as technical data under EAR Part 772.

MINIATURE LED INDICATOR

INFRARED SECURE



Model ML1618

This defense article is controlled under the International Traffic in Arms Regulations (ITAR) USML Category XII(e).

Developed for use as a function indicator, this solid-state lamp with infrared blocking lens is designed to meet the spectral requirements for Secure Lighting per DESC drawing 87019 and the U.S. Army Statement of Work. It is panel mountable with solderable leads, and includes press-lock mounting sleeve. Modified versions to meet MIL-L-85762A NVIS requirements as well as industrial requirements are available.

ML1618



FEATURES

- Infrared filtered
- Colors: red, yellow, & green
- Designed to meet CECOM secure lighting statement of work per DESC drawing 87019
- Quick panel mount seal, Press-lock
- Environmentally sealed
- Black contrasting bezel
- Non-MIL configurations available

MECHANICAL SPECIFICATIONS

Case: Aluminum, black anodized

Mounting: Via Press-Lock bushing

Terminals: Solder loops

Weight: 1.5 grams with hardware

Seal: Environmentally sealed with front panel PTFE press-lock bushing

ENVIRONMENTAL SPECIFICATIONS

Vibration: .06" D.A. or 20 Gs Peak, whichever is less, 10Hz to 2kHz, MIL STD 202, Method 204, Test Condition D

Shock: 100 Gs MIL STD 202, Method 213, Test Condition I

Moisture Resistance (Humidity): MIL STD 202, Method 106

Barometric Pressure (Reduced): 100,000 ft., MIL STD 202, Method 105, Test Condition D

Reliability: 3 x 10⁶ hours min. MTBF @ 25°C

Salt Atmosphere (Corrosion): MIL STD 202, Method 101, Test Condition B

Seal Test: MIL-DTL-3661C; 30 PSIG

ELECTRO-OPTICAL CHARACTERISTIC SPECIFICATIONS

Absolute Maximum Ratings @Temp = 25°C			
Color	Red	Yellow	Green
Forward Voltage (VDC) typical @ 20 mA	2.6	2.6	3
Peak Forward Current (mA) ①	90	60	90
DC Forward Current (mA) ②	30	20	30
Reverse Voltage (VDC) @ I _R = 100 µA	5	5	5
Power Dissipation (mW)	135	85	135
Luminous Intensity (mcd) typical @ I _F = 20 mA DC	6.0	6.0	6.0
Dominant Wave Length (nm) typical	626	585	569
Viewing Angle (2 Ø 1/2) typical	45°	45°	45°
Operating Temperature (°C)	-55 to +100	-55 to +100	-20 to +100
Storage Temperature (°C)	-55 to +100	-55 to +100	-55 to +100
Lead Soldering Temperature	260°C for 5 seconds		

Notes: ① Typical pulsing values: t_p ≤ 10 µsec, Duty cycle = 10%

② For red and green, derate linearly from 50°C @ 0.5 mA/°C. For yellow, derate linearly from 50°C @ 0.2 mA/°C

This page cleared by DoD/OSR for public release under OSR Case Number 09-S-2272 on August 06, 2009.

MINIATURE LED INDICATOR

INFRARED SECURE



This defense article is controlled under the International Traffic in Arms Regulations (ITAR) USML Category XII(e).

ORDERING INFORMATION

When ordering, show model number first, then color. If this is a special part, a factory assigned modification number will be added at the end. Consult the factory for special configurations.

Example: Basic unit with standard green color would be model ML1618-G.

ML1618 - G

Basic Model Number	LED Color
ML1618	R Red
	Y Yellow
	G Green

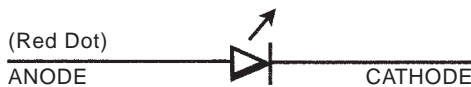
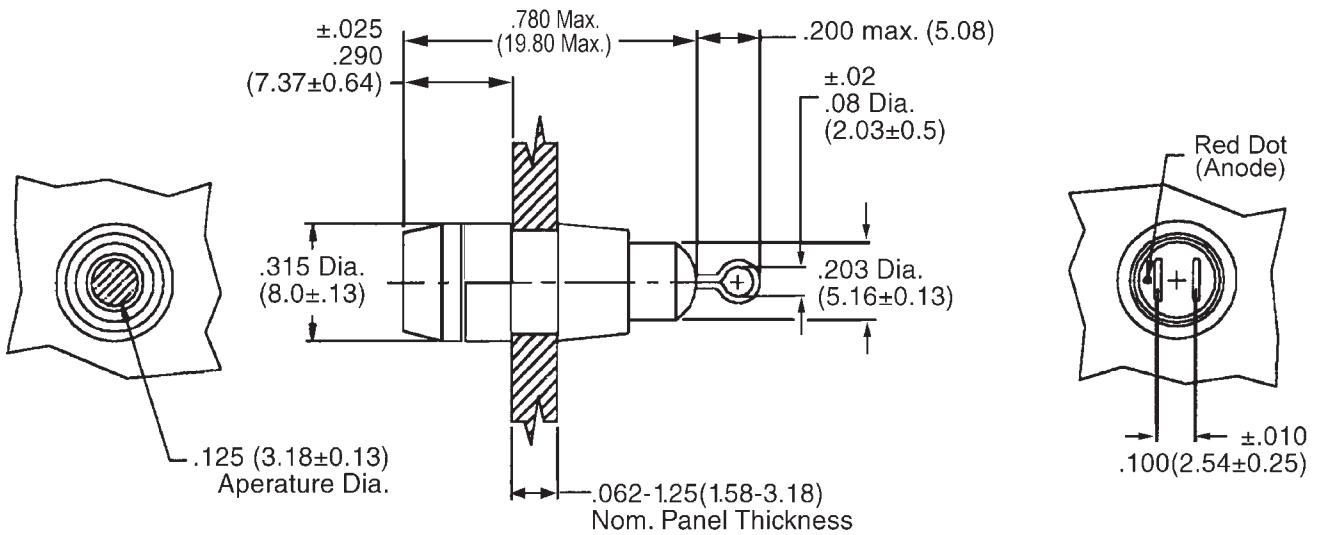

Schematic

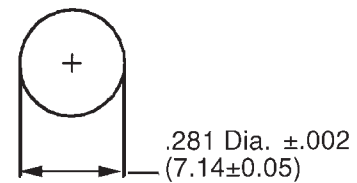

Recommended Mounting Hole

ML1618

LED INDICATORS

NOTE: Dimensions in () are mm. Tolerances: Decimals: $\pm .010 (0.25)$
Fractions: $\pm 1/64$ Mounting Torque: 5-7 in. lbs.

This page cleared by DoD/OSR for public release under OSR Case Number 09-S-2272 on August 06, 2009.

LED INDICATOR INFRARED SECURE



Model ML1619

This defense article is controlled under the International Traffic in Arms Regulations (ITAR) USML Category XII(e).

Developed for use as a function indicator, this solid-state lamp with infrared blocking lens is designed to meet the requirements of Secure Lighting per DESC drawing 87019 and the U.S. Army Statement of Work. It is panel mountable with solderable leads and includes mounting hardware.

ML1619



FEATURES

- Designed to meet CECOM secure lighting statement of work.
- Environmentally sealed
- Optional EMI protection
- Colors: red, yellow, & green
- Panel mount seal

MECHANICAL SPECIFICATIONS

Case: Aluminum, black anodized bezel with clear chromate body
Mounting: Front panel by 5/16"-32 nut and lockwasher
Weight: 1.5 grams with hardware
Seal: Environmentally sealed with front panel PTFE ring seal

ENVIRONMENTAL SPECIFICATIONS

Vibration: .06" D.A. or 20 Gs Peak, whichever is less, 10Hz to 2kHz, MIL STD 202, Method 204, Test Condition D
Shock: 100 Gs MIL STD 202, Method 213, Test Condition I
Moisture Resistance (Humidity): MIL STD 202, Method 106
Barometric Pressure (Reduced): 100,000 ft., MIL STD 202, Method 105, Test Condition D
Reliability: 3 x 10⁶ hours min. MTBF @ 25°C
Salt Atmosphere (Corrosion): MIL STD 202, Method 101, Test Condition B

ELECTRO-OPTICAL CHARACTERISTIC SPECIFICATIONS

Absolute Maximum Ratings @Temp = 25°C			
Color	Red	Yellow	Green
Forward Voltage (VDC) typical @ 20 mA	1.9	2.1	2.2
Peak Forward Current (mA) ①	90	60	90
DC Forward Current (mA) ②	30	20	30
Reverse Voltage (VDC) @ I _R = 100 µA	5	5	5
Power Dissipation (mW)	135	85	135
Luminous Intensity (mcd) typical @ I _F = 10 mA DC	2.5	5	4
Dominant Wave Length (nm) typical	626	585	571
Viewing Angle (2 Ø 1/2) typical	32°	32°	32°
Operating Temperature (°C)	-55 to +100	-55 to +100	-20 to +100
Storage Temperature (°C)	-55 to +100	-55 to +100	-55 to +100
Lead Soldering Temperature	260°C for 5 seconds		

Notes: ① Typical pulsing values: t_p ≤ 10 µsec, Duty cycle = 10%
 ② For red and green, derate linearly from 50°C @ 0.5 mA/°C. For yellow, derate linearly from 50°C @ 0.2 mA/°C

LED INDICATOR INFRARED SECURE



This defense article is controlled under the International Traffic in Arms Regulations (ITAR) USML Category XII(e).

ORDERING INFORMATION

When ordering, show model number first, then LED color, EMI screen, body finish, and the terminal style desired. If this is a special part, a factory assigned modification number will be added at the end of the ordering number. Consult the factory for special configurations.

Example: Basic model with red LED with a screen would be model ML1619-R-1-2-1.

ML1619 - R 1 2 1 ()

Basic Model Number	LED Color	EMI Screen	Body / Finish Color	Terminal Style
ML1619	R Red	0 None	2 Clear Chromate	() Straight Tin Lead
	Y Yellow	1 Screen		2 Loop Terminals
	G Green			

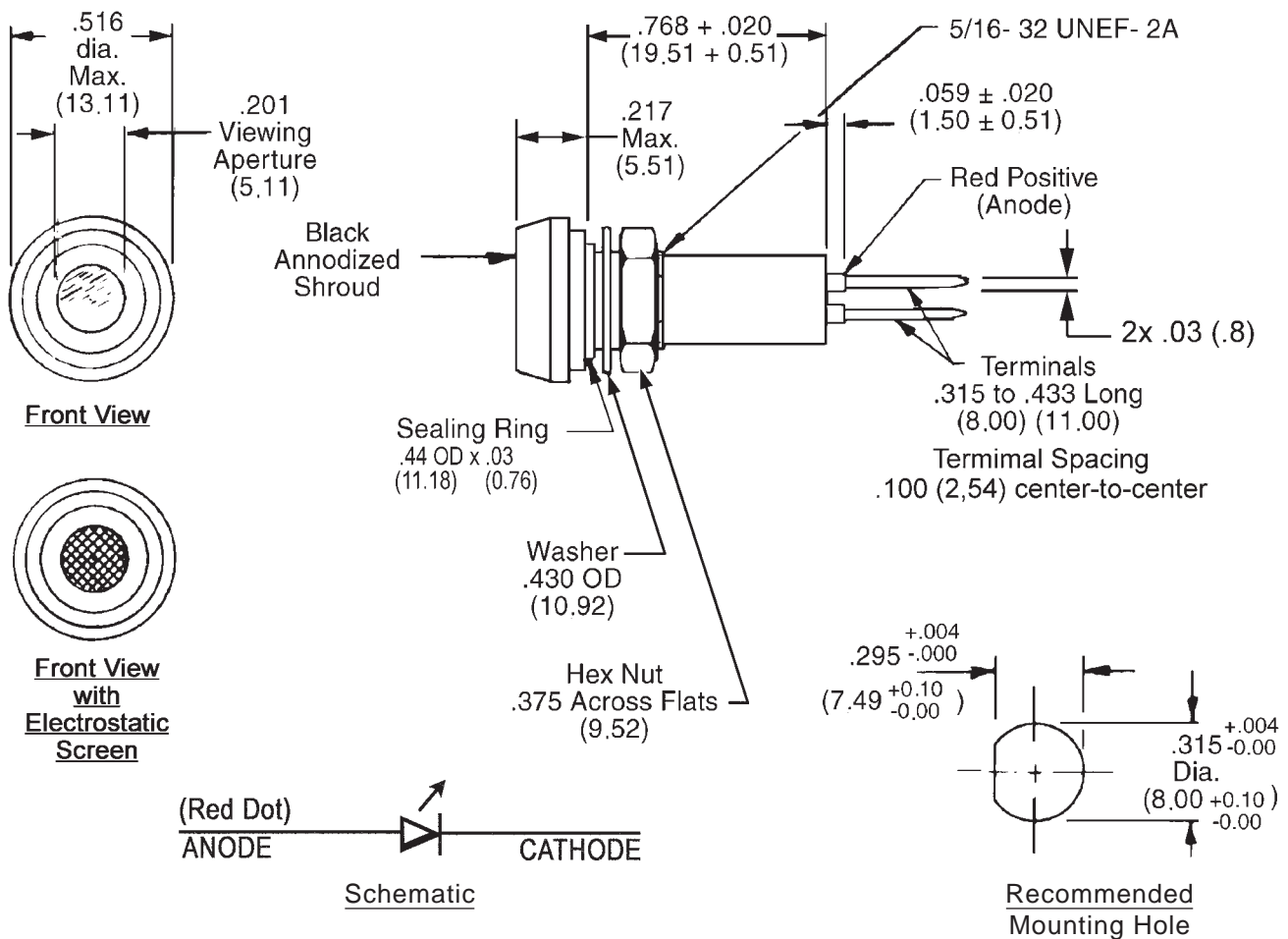

ML1619

NOTE: Dimensions in () are mm. Tolerances: Decimals: ± .010 (0.25)
 Fractions: ± 1/64 Mounting Torque: 5-7 in. lbs.

This page cleared by DoD/OSR for public release under OSR Case Number 09-S-2267 on July 23, 2009.

LED INDICATORS

LED INDICATOR

DIMMABLE INFRARED SECURE



Model MLD1619

This defense article is controlled under the International Traffic in Arms Regulations (ITAR) USML Category XII(e).

Developed for use as a function indicator, this solid-state indicator provides reduced infrared emissions and variable dimming per CECOM statement of work. It is panel mountable with solderable leads and includes hardware. It can also be produced for non-mil applications.

MLD1619



FEATURES

- Designed to meet CECOM secure lighting statement of work
- Dimmable to 0.05 foot-lamberts
- Optional EMI protection screen
- Colors: red, yellow, & green
- Panel mount seal

MECHANICAL SPECIFICATIONS

Case: Aluminum, conductive clear chromate

Cap: Aluminum, black anodized

Mounting: Front panel by 5/16"-32 nut and lockwasher

Seal: Environmentally sealed with front panel PTFE ring seal and internal O-ring seal

Terminal Style: Straight tin/lead

ENVIRONMENTAL SPECIFICATIONS

Vibration: .06" D.A. or 20 Gs Peak, whichever is less, 10Hz to 2kHz, MIL STD 202, Method 204, Test Condition D

Shock: 50 Gs MIL STD 202, Method 213, Test Condition G

Moisture Resistance (Humidity): MIL STD 202, Method 106

Barometric Pressure (Reduced): 100,000 ft., MIL STD 202, Method 105, Test Condition D

Reliability: 3 x 10⁶ hours min. MTBF @ 25°C

Salt Atmosphere (Corrosion): MIL STD 202, Method 101, Test Condition B

ELECTRO-OPTICAL CHARACTERISTIC SPECIFICATIONS

Absolute Maximum Ratings @Temp = 25°C			
Color	Red	Yellow	Green
Forward Voltage (VDC) typical @ 20 mA	1.9	2.1	2.2
Peak Forward Current (mA) ①	90	60	90
DC Forward Current (mA) ②	30	20	30
Reverse Voltage (VDC) @ I _R = 100 μA	5	5	5
Power Dissipation (mW)	135	85	135
Luminous Intensity (fL) typical @ I _F = 20 mA DC	2.5	4.0	5.0
Dominant Wave Length (nm) typical	626	585	569
Viewing Angle (2 Ø ^{1/2}) typical	30°	30°	30°
Operating Temperature (°C)	-55 to +100	-55 to +100	-20 to +100
Storage Temperature (°C)	-55 to +100	-55 to +100	-55 to +100
Lead Soldering Temperature	260°C for 5 seconds		

Notes: ① Typical pulsing values: t_p ≤ 10 μsec, Duty cycle = 10%

② For red and green, derate linearly from 50°C @ 0.5 mA/°C. For yellow, derate linearly from 50°C @ 0.2 mA/°C

This page cleared by DoD/OSR for public release under OSR Case Number 09-S-2269 on July 23, 2009.

LED INDICATOR

DIMMABLE INFRARED SECURE



This defense article is controlled under the International Traffic in Arms Regulations (ITAR) USML Category XII(e).

ORDERING INFORMATION

When ordering, show model number first, followed by EMI screen, LED color, lens type, and the terminal style desired. If this is a special part, a factory assigned modification number will be added at the end of the ordering number. Consult the factory for special configurations.

Example: Basic model with an EMI screen, red LED, a non-diffused lens, and straight terminals is MLD1619E-R-ND-ST.

MLD1619E - R - ND - ST

Basic Model Number	EMI Screen	LED Color	Lens Type	Terminal Style
MLD1619	() None	R Red	ND Non-diffused	ST Straight Leads
	E Screen	Y Yellow	D Diffused	
		G Green		

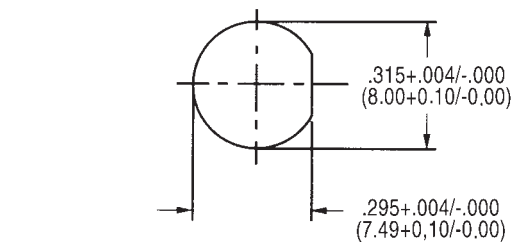
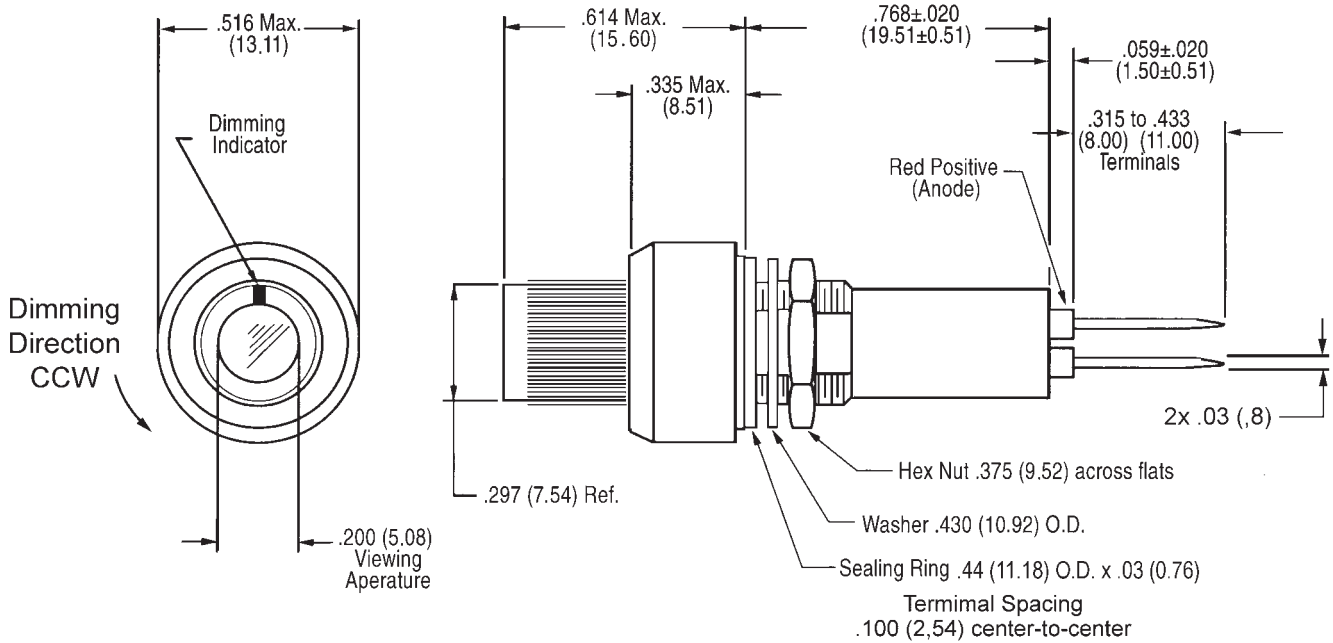

Recommended Mounting Hole

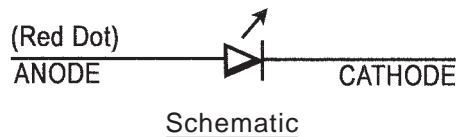

MLD1619

NOTE: Dimensions in () are mm. Tolerances: Decimals: ± .010 (0.25)
Fractions: ± 1/64 Mounting Torque: 5-7 in. lbs.

This page cleared by DoD/OSR for public release under OSR Case Number 09-S-2269 on July 23, 2009.

LED INDICATORS

MINIATURE LED INDICATOR PANEL MOUNT



Models ML1620 & ML1630

Designed for use as function indicators on aircraft, test equipment, machine tools, and wherever severe environmental conditions need to be met, especially vibration and EMI.

FEATURES

- Performs in severe environments
- Low power use
- High efficiency
- Rugged construction
- Readily mounted on panel
- Optional EMI screen
- Optional internal resistor

MECHANICAL SPECIFICATIONS

Case: Aluminum, black anodized front with conductive clear chromate back

Mounting: Front panel by 5/16"-32 nut and lockwasher

Seal: Environmentally sealed. Added front panel O-ring seal for model ML1630.

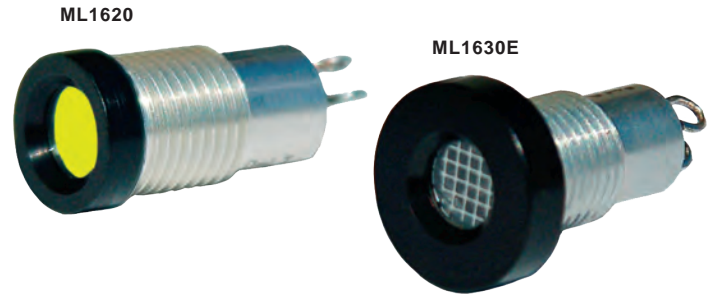

ENVIRONMENTAL SPECIFICATIONS

Vibration: .06" D.A. or 20 Gs Peak, whichever is less, 10Hz to 2kHz, MIL STD 202, Method 204, Test Condition D

Shock: 100 Gs MIL STD 202, Method 213, Test Condition I

Moisture Resistance (Humidity): MIL STD 202, Method 106

Barometric Pressure (Reduced): 100,000 ft., MIL STD 202, Method 105, Test Condition D

Reliability: 3 x 10⁶ hours min. MTBF @ 25°C

Salt Atmosphere (Corrosion): MIL STD 202, Method 101, Test Condition B

ELECTRO-OPTICAL CHARACTERISTIC SPECIFICATIONS*

Absolute Maximum Ratings @Temp = 25°C				
Color		Red	Yellow	Green
Forward Voltage (VDC) typical @ 20 mA (no resistor)		1.9	2.1	2.2
Peak Forward Current (mA DC) ①		90	60	90
DC Forward Current (mA DC) ② (no resistor)		30	20	30
Reverse Voltage (VDC) @ I _R = 100 μA		5	5	5
Power Dissipation (mW)		135	85	135
Luminous Intensity (mcd) typical @ I _F = 10 mA DC	Non-diffused	60	40	50
	Diffused	12	12	12
Dominant Wave Length (nm) typical		626	585	569
Viewing Angle (2 Ø ^{1/2}) typical	Non-diffused	30°	30°	30°
	Diffused	60°	60°	60°
Operating Temperature (°C)		-55 to +100	-55 to +100	-20 to +100
Storage Temperature (°C)		-55 to +100	-55 to +100	-55 to +100
Lead Soldering Temperature		260°C for 5 seconds		

Notes: ① Typical pulsing values: t_p ≤ 10 μsec, Duty cycle = 10%

② For red and green, derate linearly from 50°C @ 0.5 mA/°C. For yellow, derate linearly from 50°C @ 0.2 mA/°C

*These characteristics reflect the baseline straight terminal model. Variations may imply a difference in luminous characteristics and/or operability features. Please contact the EDI Sales Department for more information.

This page consists of basic marketing information that is not defined as technical data under EAR Part 772.

MINIATURE LED INDICATOR PANEL MOUNT



ORDERING INFORMATION

When ordering, show basic part number first, then EMI screen, LED color, lens type, and voltage desired. If this is a special part, a factory assigned modification number will be added at the end of the ordering number. Consult the factory for special configurations.

Example: Basic model with an O-ring panel seal, an EMI screen, a red LED, a diffused lens, straight leads, and no internal resistor would be ML1630E-R-D-ST-(-)-(-).

ML1630E - R - D - ST - () - ()

Standard factory options are designated by "-Sxxx"

Basic Model Number	EMI Screen	LED Color	Lens Type	Terminal Style	Internal Resistor
ML1620 (w/o O-ring)	() None	R Red	ND Non-diffused	ST Straight Leads	() No Resistor
ML1630 (with O-ring)	E Screen	Y Yellow	D Diffused	LT Loop Terminals	5 5V*
		G Green			12 12V*
					14 14V*
					24 24V*
					28 28V*

*Operating temperature for internal resistor option is -40°C to +85°C

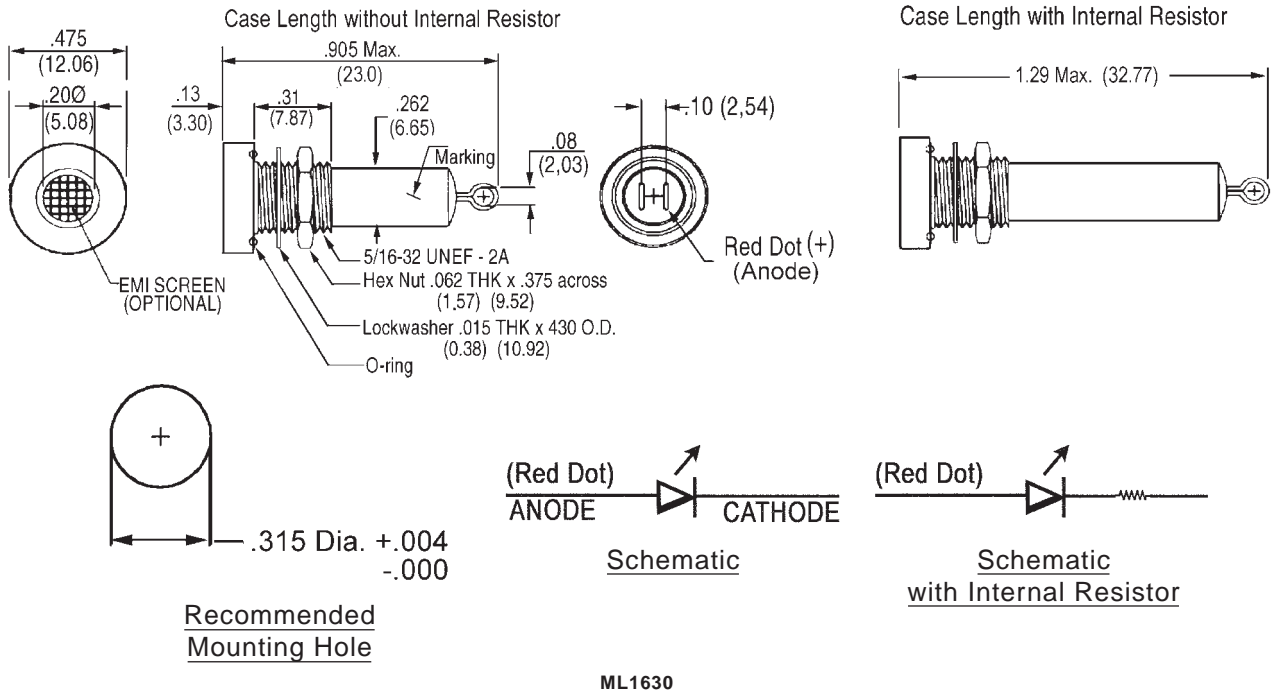
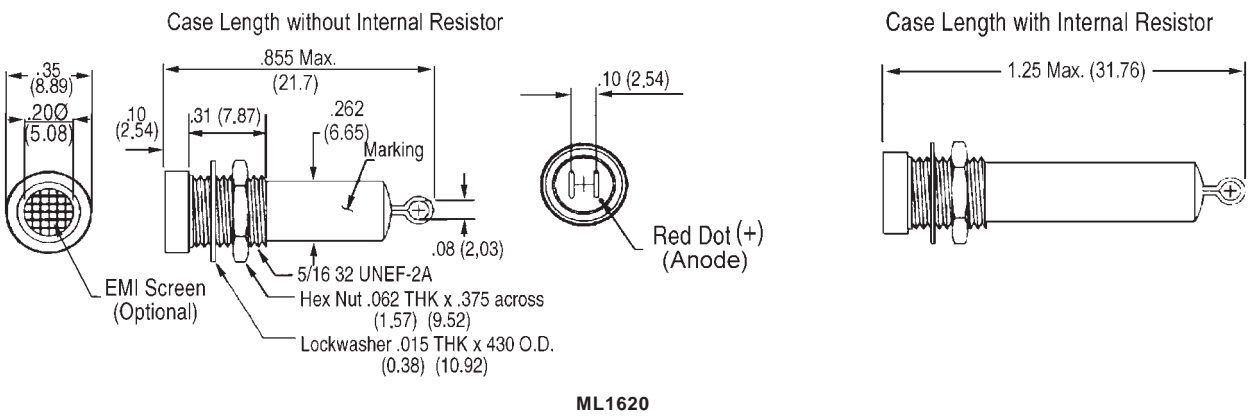

NOTE: Dimensions in () are mm. Tolerances: Decimals: ± .010 (0.25)
Fractions: ± 1/64 Mounting Torque: 5-7 in. lbs.

This page consists of basic marketing information that is not defined as technical data under EAR Part 772.

MINIATURE LED INDICATOR PANEL MOUNT



Models ML1620-S & ML1630-S

Designed for use as function indicators on aircraft, test equipment, machine tools, and wherever severe environmental conditions need to be met, especially vibration and EMI.

FEATURES

- Performs in severe environments
- Low power use
- High efficiency
- High luminosity
- Rugged construction
- Readily mounted on panel
- Optional EMI screen

MECHANICAL SPECIFICATIONS

Case: Aluminum, black anodized front with conductive clear chromate back

Mounting: Front panel by 5/16"-32 nut and lockwasher

Seal: Environmentally sealed. Added front Panel O-ring seal for model ML1630.

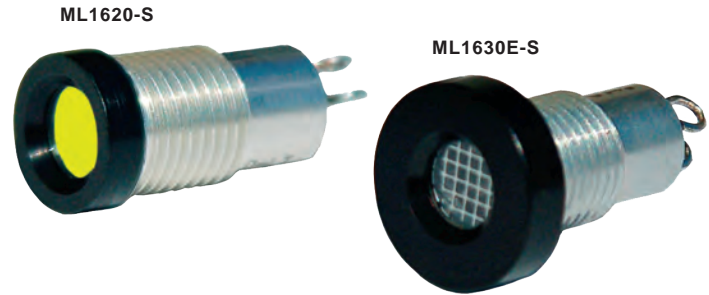

ENVIRONMENTAL SPECIFICATIONS

Vibration: .06" D.A. or 20 Gs Peak, whichever is less, 10Hz to 2kHz, MIL STD 202, Method 204, Test Condition D

Shock: 100 Gs MIL STD 202, Method 213, Test Condition I

Moisture Resistance (Humidity): MIL STD 202, Method 106

Barometric Pressure (Reduced): 100,000 ft., MIL STD 202, Method 105, Test Condition D

Reliability: 3 x 10⁶ hours min. MTBF @ 25°C

Salt Atmosphere (Corrosion): MIL STD 202, Method 101, Test Condition B

ELECTRO-OPTICAL CHARACTERISTIC SPECIFICATIONS

Absolute Maximum Ratings @Temp = 25°C			
Color	Red	Yellow	Green
Forward Voltage (VDC) typical @ 20 mA	1.9	2.1	2.2
DC Forward Current (mA DC)	30	30	25
Reverse Voltage (VDC) @ I _R = 100 µA	5	5	5
Power Dissipation (mW) ①	100	105	105
Luminous Intensity (mcd) typical @ I _F = 20 mA DC Diffused	250	300	40
Dominant Wave Length (nm) typical	640	588	568
Viewing Angle (2 Ø ^{1/2}) typical Diffused	60°		
Operating Temperature (°C)	-40 to +85		
Storage Temperature (°C)	-55 to +100		
Lead Soldering Temperature	260°C for 5 seconds		

Notes: ① Power derating: derate linearly from 25°. For Green and Yellow: -1.2mW/°C. For Red: -1.3mW/°C

This page consists of basic marketing information that is not defined as technical data under EAR Part 772.

MINIATURE LED INDICATOR PANEL MOUNT



ORDERING INFORMATION

When ordering, show basic part number first, then EMI screen, LED color, and lens type. If this is a special part, a factory assigned modification number will be added at the end of the ordering number. Consult the factory for special configurations.

Example: Basic model with an O-ring panel seal, an EMI screen, a red LED, a diffused lens, and straight leads would be ML1630E-SR-D-ST-(-)-(-)

ML1630E - SR - D - ST - () - ()

Standard factory options are designated by "-Sxxx"

Basic Model Number	EMI Screen	LED Color	Lens Type	Terminal Style	Internal Resistor
ML1620 (w/o O-ring)	() None	SR Red	ND Non-diffused	ST Straight Leads	() No Resistor
ML1630 (with O-ring)	E Screen	SY Yellow SG Green	D Diffused	LT Loop Terminals	5 5V* 12 12V* 14 14V* 24 24V* 28 28V*

*Operating temperature for internal resistor option is -40°C to +85°C

Case Length without Internal Resistor

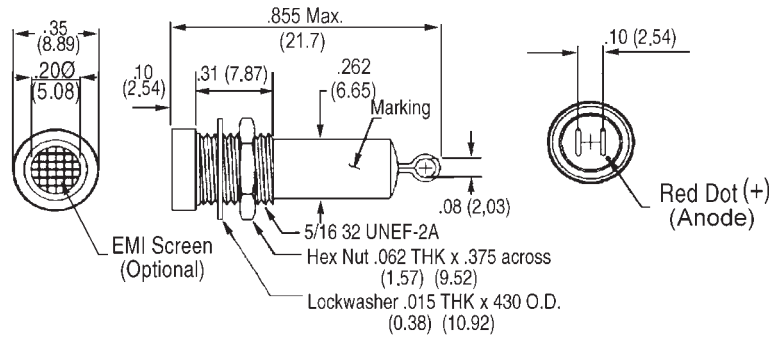

ML1620-S

Case Length without Internal Resistor

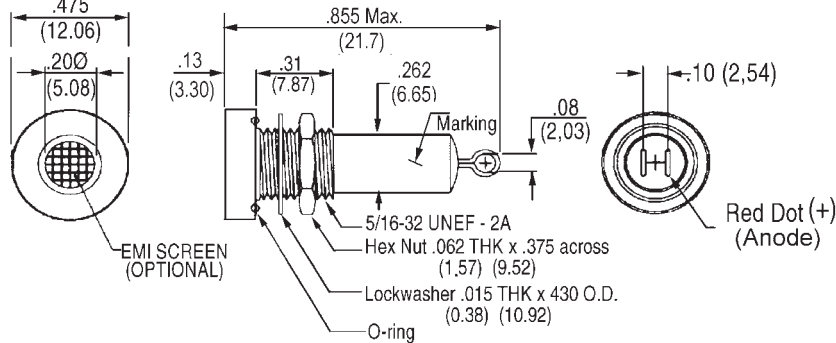

Recommended Mounting Hole

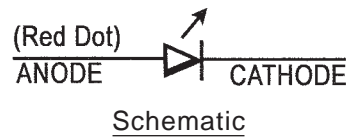

ML1630-S

NOTE: Dimensions in () are mm. Tolerances: Decimals: ± .010 (0.25)
Fractions: ± 1/64 Mounting Torque: 5-7 in. lbs.

This page consists of basic marketing information that is not defined as technical data under EAR Part 772.

LED INDICATOR BI-COLOR PANEL MOUNT



Models ML1622 & ML1632

Designed for use as function indicators on aircraft, test equipment, machine tools and wherever severe environmental conditions need to be met, especially vibration and EMI.

FEATURES

- Multiple status indication within a single package
- Performs in severe environments
- Low power use
- Rugged construction
- Panel mounted
- Optional EMI screen
- Internal resistor available

MECHANICAL SPECIFICATIONS

Case: Aluminum, black anodized front with clear chromate back

Mounting: Front panel by 5/16"-32 nut and lockwasher

Seal: Environmentally sealed. Added front panel O-ring seal for model ML1632.



ENVIRONMENTAL SPECIFICATIONS

Vibration: .06" D.A. or 20 Gs Peak, whichever is less, 10Hz to 2kHz, MIL STD 202, Method 204, Test Condition D

Shock: 100 Gs MIL STD 202, Method 213, Test Condition I

Moisture Resistance (Humidity): MIL STD 202, Method 106

Barometric Pressure (Reduced): 100,000 ft., MIL STD 202, Method 105, Test Condition D

Reliability: 3 x 10⁶ hours min. MTBF @ 25°C

Salt Atmosphere (Corrosion): MIL STD 202, Method 101, Test Condition B

ELECTRO-OPTICAL CHARACTERISTIC SPECIFICATIONS*

Absolute Maximum Ratings @Temp = 25°C						
Color	Red / Green		Yellow / Green		Super Red / Super Green	
Forward Voltage (VDC) typical @ 20 mA	2.1	2.1	2.1	2.1	1.85	2.2
Peak Forward Current (mA) ①	150	150	150	150	155	140
DC Forward Current (mA)	30	25	30	25	30	25
Power Dissipation (mW) ②	105	105	105	105	75	62.5
Luminous Intensity (mcd) typical @ I _F = 20 mA	30	20	20	20	100	30
Dominant Wave Length (nm) typical	625	568	588	568	640	568
Viewing Angle (2 Ø ^{1/2}) typical	60°					
Operating Temperature (°C)	-40 to +85					
Storage Temperature (°C)	-55 to +100			-40 to +85		
Lead Soldering Temperature	260°C for 5 seconds					
Notes: ① Typical pulsing values: t _p ≤ 10 µsec, Duty cycle = 10% ② Derate at 1.6 mW/°C above +25°C Ambient						

*These characteristics reflect the baseline model. Variations may imply a difference in luminous characteristics and/or operability features. Please contact the EDI Sales Department for more information.

This page consists of basic marketing information that is not defined as technical data under EAR Part 772.

LED INDICATOR BI-COLOR PANEL MOUNT



ORDERING INFORMATION

When ordering, show basic part number first, then EMI screen, LED color, lens type, terminal style, and voltage. If this is a special part, a factory assigned modification number will be added at the end of the ordering number. Consult the factory for special configurations.

Example: Basic model with O-ring panel seal, an EMI screen, with a yellow/green LED, a diffused lens, loop terminals, and 24 volt internal resistor would be an ML1632E-Y/G-D-LT-24.

ML1632E - Y/G - D - LT - 24 - ()

Standard factory options are designated by "-Sxxx"

Basic Model Number	EMI Screen	LED Color	Lens Type	Terminal Style	Internal Resistor	
ML1622 (w/o O-ring)	() None	R/G Red/Green	D Diffused	ST Straight Leads	() No Resistor	
ML1632 (with O-ring)	E Screen	Y/G Yellow/Green		LT Loop Terminals	5	5V
					12	12V
					14	14V
					24	24V
					28	28V

Without Internal Resistor

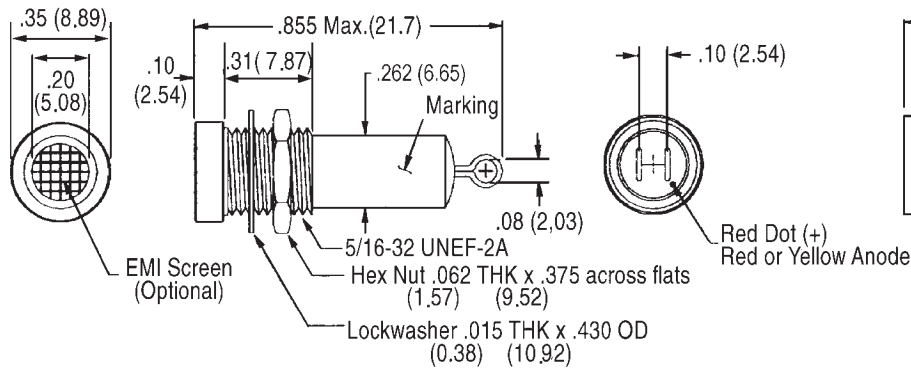

ML1622

With Internal Resistor

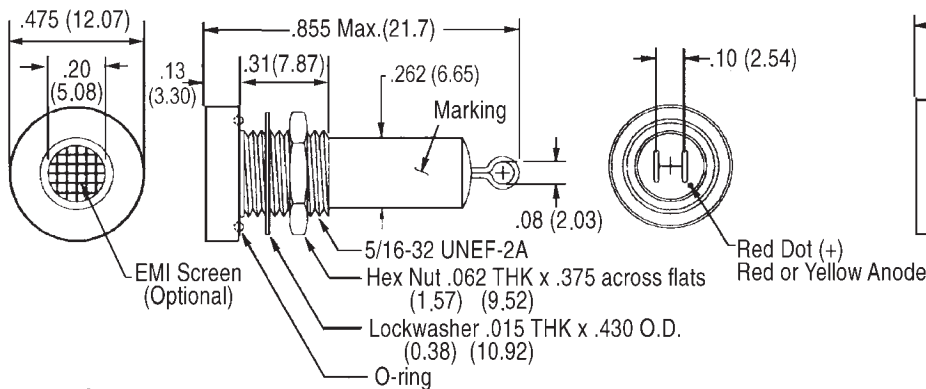
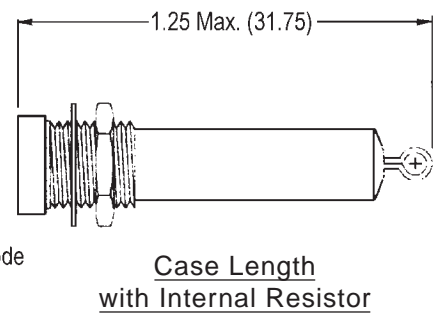

Case Length with Internal Resistor



Recommended Mounting Hole

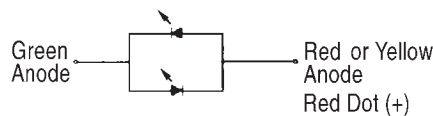

Schematic

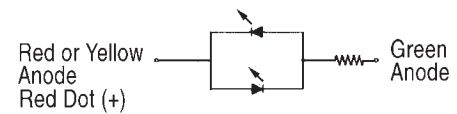

Schematic with Internal Resistor

ML1632 with front panel O-ring

NOTE: Dimensions in () are mm. Tolerances: Decimals: ± .010 (0.25)
Fractions: ± 1/64 Mounting Torque: 5-7 in. lbs.

This page consists of basic marketing information that is not defined as technical data under EAR Part 772.

LED INDICATOR

THREE LEAD BI-COLOR PANEL MOUNT



LED INDICATORS

Models ML1623-S & ML1633-S

Designed for use as function indicators on aircraft, test equipment, machine tools and wherever severe environmental conditions need to be met, especially vibration and EMI.

FEATURES

- Multiple status indication within a single package
- Performs in severe environments
- Low power use
- Rugged construction
- Panel mounted
- Optional EMI screen

MECHANICAL SPECIFICATIONS

Case: Aluminum, black anodized front with clear chromate back

Mounting: Front panel by 5/16"-32 nut and lockwasher

Seal: Environmentally sealed. Added front panel O-ring seal for model ML1633.



ENVIRONMENTAL SPECIFICATIONS

Vibration: .06" D.A. or 20 Gs Peak, whichever is less, 10Hz to 2kHz, MIL STD 202, Method 204, Test Condition D

Shock: 100 Gs MIL STD 202, Method 213, Test Condition I

Moisture Resistance (Humidity): MIL STD 202, Method 106

Barometric Pressure (Reduced): 100,000 ft., MIL STD 202, Method 105, Test Condition D

Reliability: 3 x 10⁶ hours min. MTBF @ 25°C

Salt Atmosphere (Corrosion): MIL STD 202, Method 101, Test Condition B

ELECTRO-OPTICAL CHARACTERISTIC SPECIFICATIONS

Absolute Maximum Ratings @Temp = 25°C					
Color		Red / Green		Yellow / Green	
Forward Voltage (VDC) typical @ 20 mA		1.7	2.2	2.1	2.2
Peak Forward Current (mA) ①		150	150	150	150
DC Forward Current (mA)		30	25	30	25
Reverse Voltage (VDC) @ I _R = 100 μA		5	5	5	5
Power Dissipation (mW) ②		100	105	100	105
Luminous Intensity (mcd) typical @ I _F = 20 mA DC	Non-diffused	500	140	NA	NA
	Diffused	200	60	150	60
Dominant Wave Length (nm) typical		640	568	588	568
Viewing Angle (2 Ø ^{1/2}) typical	Non-diffused	30°		30°	
	Diffused	60°		60°	
Operating Temperature (°C)		-40 to +85		-40 to +85	
Storage Temperature (°C)		-55 to +100		-55 to +100	
Lead Soldering Temperature		260°C for 5 seconds			

Notes: ① Typical pulsing values: t_p ≤ 10 μsec, Duty cycle = 10%
 ② Derate at 1.6 mW/°C above +25°C Ambient

*These characteristics reflect the baseline model. Variations may imply a difference in luminous characteristics and/or operability features. Please contact the EDI Sales Department for more information.

This page consists of basic marketing information that is not defined as technical data under EAR Part 772.

LED INDICATOR THREE LEAD BI-COLOR PANEL MOUNT



ORDERING INFORMATION

When ordering, show model number first, followed by EMI screen, then LED color, lens type, and terminal style. If this is a special part, a factory assigned modification number will be added at the end of the ordering number. Consult the factory for special configurations.

Example: Basic model without an O-ring panel seal, with an EMI screen, a yellow/green LED, a diffused lens, and loop terminals would be an ML1623E-SY/SG-D-LT.

ML1623E - SY/SG - D - LT - ()

Standard factory options are designated by "-Sxxx"

Basic Model Number	EMI Screen	LED Color	Lens Type	Terminal Style
ML1623 (w/o O-ring)	() None	SR/SG Red/Green	ND Non-diffused	ST Straight Leads
ML1633 (with O-ring)	E Screen	SY/SG Yellow/Green	D Diffused	LT Loop Terminals

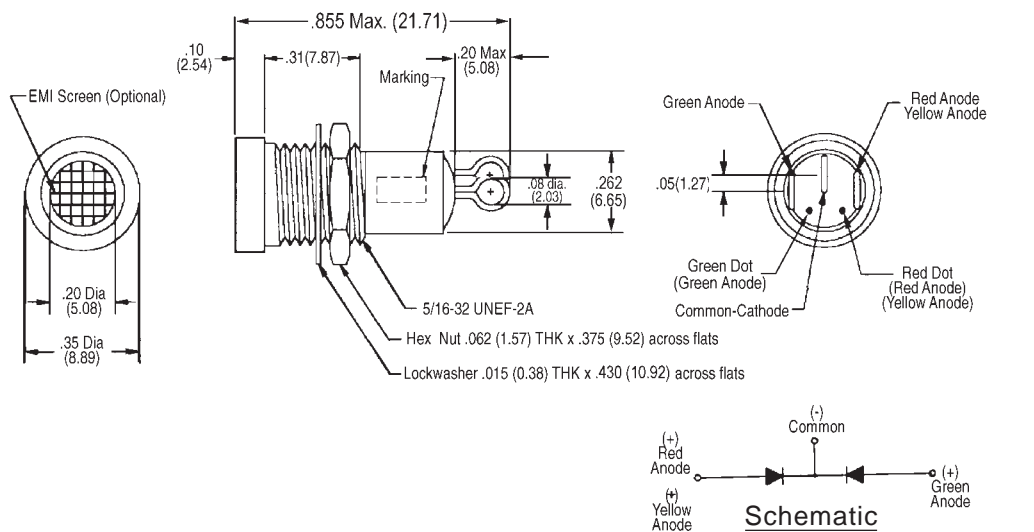

ML1623-S

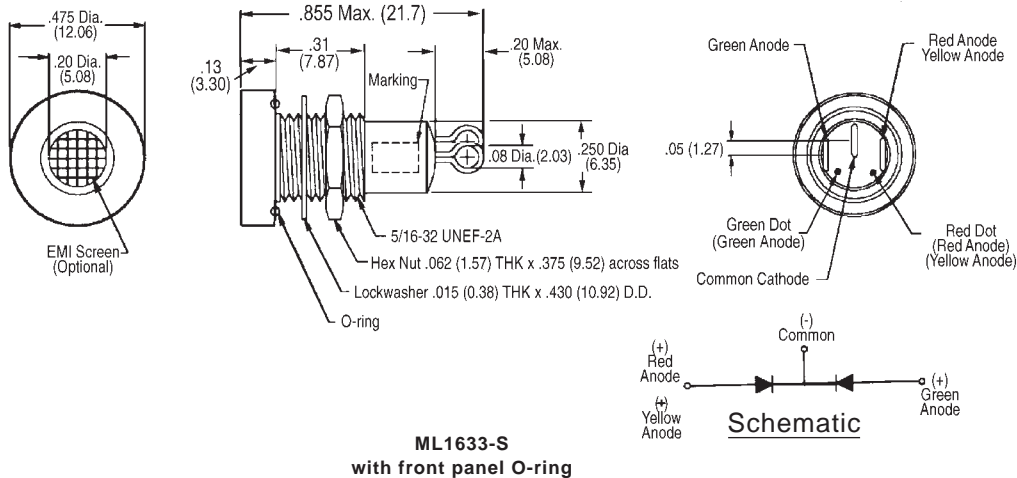

ML1633-S
with front panel O-ring

NOTE: Dimensions in () are mm. Tolerances: Decimals: ± .010 (0.25)
Fractions: ± 1/64 Mounting Torque: 5-7 in. lbs.

This page consists of basic marketing information that is not defined as technical data under EAR Part 772.

LED INDICATOR TRI-COLOR REAR-MOUNT



Model ML1631

Developed for use as a status indicator, the ML1631 was designed to survive in the most severe environments. The small size and rugged package make it ideal for applications where status indication is critical to the operation of your equipment. The environmentally sealed case includes an O-ring panel seal that insures the integrity of your system. The ML1631 comes complete with fluorosilicone O-ring and mounting hardware.

FEATURES

- Multiple status indication within a single package
- Ideal for rugged environments
- Environmentally sealed
- Panel-mount seal
- Colors: red, green and blue
- Compact case design
- EMI screen
- Decorative bezel
- Wide viewing angle

MECHANICAL SPECIFICATIONS

Case: Aluminum Clear chromate

Mounting: Rear-mount by 5/16"-32 nut and lockwasher

O-Ring: Fluorosilicone rubber



ENVIRONMENTAL SPECIFICATIONS

Vibration: .06" D.A. or 20 Gs Peak, whichever is less, 10Hz to 2kHz, MIL STD 202, Method 204, Test Condition D

Shock: 100 Gs MIL STD 202, Method 213, Test Condition I

Moisture Resistance (Humidity): MIL STD 202, Method 106

Barometric Pressure (Reduced): 100,000 ft., MIL STD 202, Method 105, Test Condition D

Reliability: 3 x 10⁶ hours min. MTBF @ 25°C

Salt Atmosphere (Corrosion): MIL STD 202, Method 101, Test Condition B

ELECTRO-OPTICAL CHARACTERISTIC SPECIFICATIONS

Absolute Maximum Ratings @Temp = 25°C			
Color	Red	Green	Blue
Forward Voltage (VDC) typical @ 20 mA	1.9	3.3	3.3
DC Forward Current (mA) ①	30	25	30
Reverse Voltage (VDC) @ I _R = 100 μA	5	5	5
Power Dissipation (mW)	75	102	120
Luminous Intensity (mcd) typical @ I _F = 20 mA	60	125	85
Dominant Wave Length (nm) typical	630	525	465
Viewing Angle	130°		
Operating Temperature (°C)	-40 to +85		
Storage Temperature (°C)	-55 to +100		
Lead Soldering Temperature	260°C for 5 seconds		

Notes: ① Derate linearly from 25°C @ -0.4 mA/°C.

This page consists of basic marketing information that is not defined as technical data under EAR Part 772.

LED INDICATOR TRI-COLOR REAR-MOUNT



ORDERING INFORMATION

When ordering, show model number first, followed by EMI screen, then LED colors, lens style, and terminal style. If this part requires customization, a special factory assigned modification number will be added at the end of the ordering number. Consult the factory for special configurations.

Example: Basic model with an EMI screen, with a red/green/blue LED, a diffused lens, and straight leads would be ML1631E-RGB-D-ST.

ML1631E - RGB - D - ST

Basic Model Number	EMI Screen	LED Color	Lens Type	Terminal Style
ML1631	E Screen	RGB Red, Green, Blue	D Diffused	ST Straight Leads

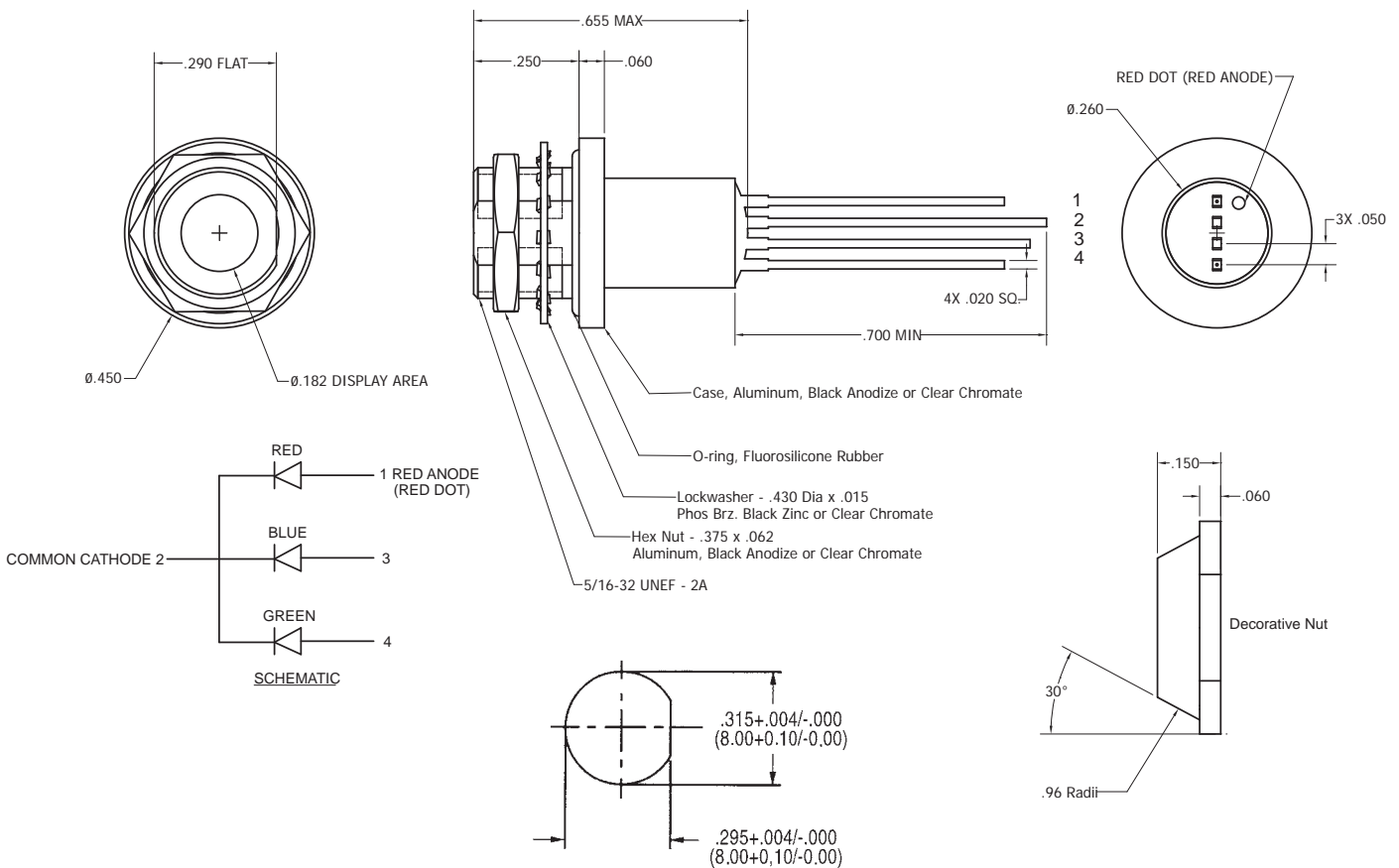

Recommended Mounting Hole

ML1631

NOTE: Dimensions in () are mm. Tolerances: Decimals: $\pm .010$ (0.25)
Fractions: $\pm 1/64$ Mounting Torque: 5-7 in. lbs.

This page consists of basic marketing information that is not defined as technical data under EAR Part 772.

LED INDICATOR BI-COLOR REAR-MOUNT



Model ML1634

Designed for use as function indicators on aircraft, test equipment, machine tools and wherever severe environmental conditions need to be met, especially vibration and EMI.

FEATURES

- Multiple status indication within a single package
- Performs in severe environments
- Colors: red/green, yellow/green
- Rugged construction
- Panel mounted
- Optional EMI screen
- Decorative bezel

MECHANICAL SPECIFICATIONS

Case: Aluminum, black anodized, standard. Clear chromate case with EMI screen option.

Mounting: Rear-mount by 5/16"-32 nut and lockwasher

Seal: Environmentally sealed. Added front panel fluorosilicone O-ring.

Panel Thickness: 0.118" max.



Standard Case

ENVIRONMENTAL SPECIFICATIONS

Vibration: .06" D.A. or 20 Gs Peak, whichever is less, 10Hz to 2kHz, MIL STD 202, Method 204, Test Condition D

Shock: 100 Gs MIL STD 202, Method 213, Test Condition I

Moisture Resistance (Humidity): MIL STD 202, Method 106

Barometric Pressure (Reduced): 100,000 ft., MIL STD 202, Method 105, Test Condition D

Reliability: 3 x 10⁶ hours min. MTBF @ 25°C

Salt Atmosphere (Corrosion): MIL STD 202, Method 101, Test Condition B

ELECTRO-OPTICAL CHARACTERISTIC SPECIFICATIONS

Absolute Maximum Ratings @Temp = 25°C						
Color	Red / Green		Yellow / Green		Super Red / Super Green	
Forward Voltage (VDC) typical @ 20 mA	1.9	2.2	2.1	2.2	1.85	2.2
DC Forward Current (mA)	30	25	30	25	30	25
Power Dissipation (mW) ①	105	105	105	105	75	62.5
Luminous Intensity (mcd) typical @ I _F = 20 mA DC	30	20	20	20	100	30
Dominant Wave Length (nm) typical	640	568	588	568	640	568
Viewing Angle (2 Ø ^{1/2}) typical	60°					
Operating Temperature (°C)	-40 to +85					
Storage Temperature (°C)	-55 to +100			-40 to +85		
Lead Soldering Temperature	260°C for 5 seconds					
Notes: ① Derate linearly from 25°C at -1.2 mW/°C						

This page consists of basic marketing information that is not defined as technical data under EAR Part 772.

LED INDICATOR BI-COLOR REAR-MOUNT



ORDERING INFORMATION

When ordering, show basic part number first, then EMI screen, LED color, lens type, and terminal style. If this is a special part, a factory assigned modification number will be added at the end of the ordering number. Consult the factory for special configurations.

Example: Basic model with an EMI screen, with a red/green LED, a diffused lens, and straight terminals would be an ML1634E-R/G-D-ST.

ML1634E - R/G - D - ST - ()

Standard factory options are designated by "-Sxxx"

Basic Model Number	EMI Screen	LED Color	Lens Type	Terminal Style
ML1634	() None	R/G Red/Green	D Diffused	ST Straight Leads
	E Screen	Y/G Yellow/Green		LT Loop Terminals
		SR/SG Red/Green		

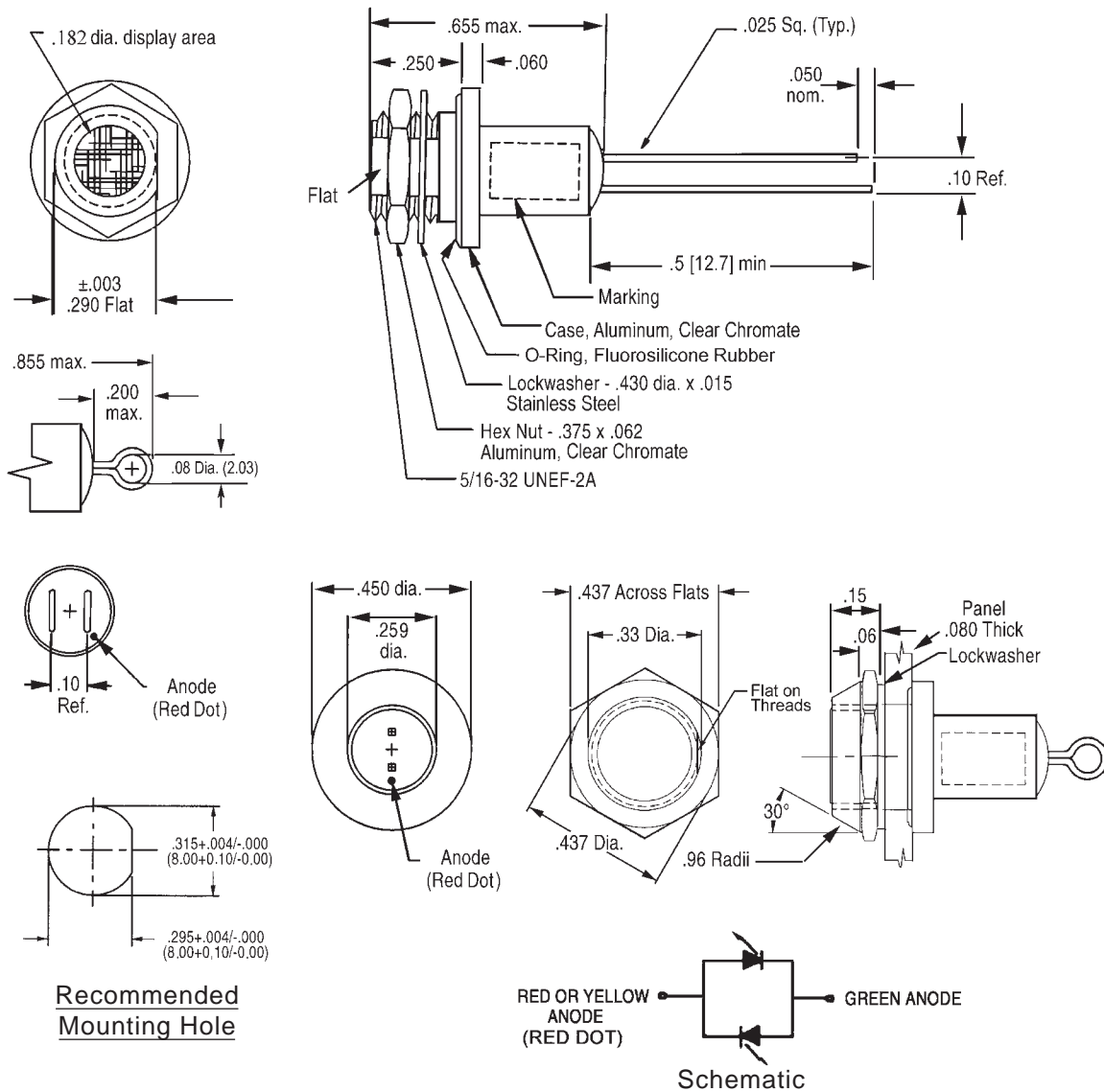

ML1634

NOTE: Dimensions in () are mm. Tolerances: Decimals: ± .010 (0.25)
Fractions: ± 1/64 Mounting Torque: 5-7 in. lbs.

This page consists of basic marketing information that is not defined as technical data under EAR Part 772.

LED INDICATOR

THREE LEAD BI-COLOR REAR-MOUNT



Model ML1635

Developed for use as a status indicator, the ML1635 was designed to survive in the most severe environments. The small size and rugged package make it ideal for applications where status indication is critical to the operation of your equipment. The environmentally sealed case includes an O-ring panel seal that insures the integrity of your system. Comes complete with Fluorosilicone O-ring and mounting hardware.

FEATURES

- Multiple status indication within a single package
- Environmentally sealed
- Panel mount seal
- Colors: red/green & yellow/green
- Compact case design
- EMI screen option
- Decorative bezel

MECHANICAL SPECIFICATIONS

Case: Aluminum, black anodized, standard. Clear chromate case with EMI screen option.

Mounting: Rear-mount by 5/16"-32 nut and lockwasher

O-ring: Fluorosilicone rubber



ML1635E

Case with EMI Screen

ENVIRONMENTAL SPECIFICATIONS

Vibration: .06" D.A. or 20 Gs Peak, whichever is less, 10Hz to 2kHz, MIL STD 202, Method 204, Test Condition D

Shock: 100 Gs MIL STD 202, Method 213, Test Condition I

Moisture Resistance (Humidity): MIL STD 202, Method 106

Barometric Pressure (Reduced): 100,000 ft., MIL STD 202, Method 105, Test Condition D

Reliability: 3 x 10⁶ hours min. MTBF @ 25°C

Salt Atmosphere (Corrosion): MIL STD 202, Method 101, Test Condition B

ELECTRO-OPTICAL CHARACTERISTIC SPECIFICATIONS

Absolute Maximum Ratings @Temp = 25°C				
Color	Red / Green		Yellow / Green	
Forward Voltage (VDC) typical @ 20 mA	2.0	2.1	2.0	2.1
DC Forward Current (mA)	30	25	30	25
Reverse Voltage (VDC) @ I _R = 100 µA	5	5	5	5
Power Dissipation (mW) ①	100	105	105	105
Luminous Intensity (mcd) typical @ I _F = 20 mA DC	Diffused		200	60
Dominant Wave Length (nm) typical	630	570	588	570
Viewing Angle	Diffused		60°	
Operating Temperature (°C)	-40 to +85			
Storage Temperature (°C)	-40 to +85			
Lead Soldering Temperature	260°C for 5 seconds			

Notes: ① Derate linearly from 25°C at -1.2 mW/°C

This page consists of basic marketing information that is not defined as technical data under EAR Part 772.

LED INDICATOR

THREE LEAD BI-COLOR REAR-MOUNT



ORDERING INFORMATION

When ordering, show model number first, followed by EMI screen, then LED color, lens style, and terminal style. If this is a special part, a factory assigned modification number will be added at the end of the ordering number. Consult the factory for special configurations.

Example: Basic model with an EMI screen, with a yellow/green LED, a diffused lens, and straight leads would be ML1635E-SY/SG-D-ST.

ML1635E - SY/SG - D - ST - ()

Standard factory options are designated by "-Sxxx"

Basic Model Number	EMI Screen	LED Color	Lens Type	Terminal Style
ML1635	() None E Screen	SR/SG Red/Green SY/SG Yellow/Green	D Diffused	ST Straight Leads

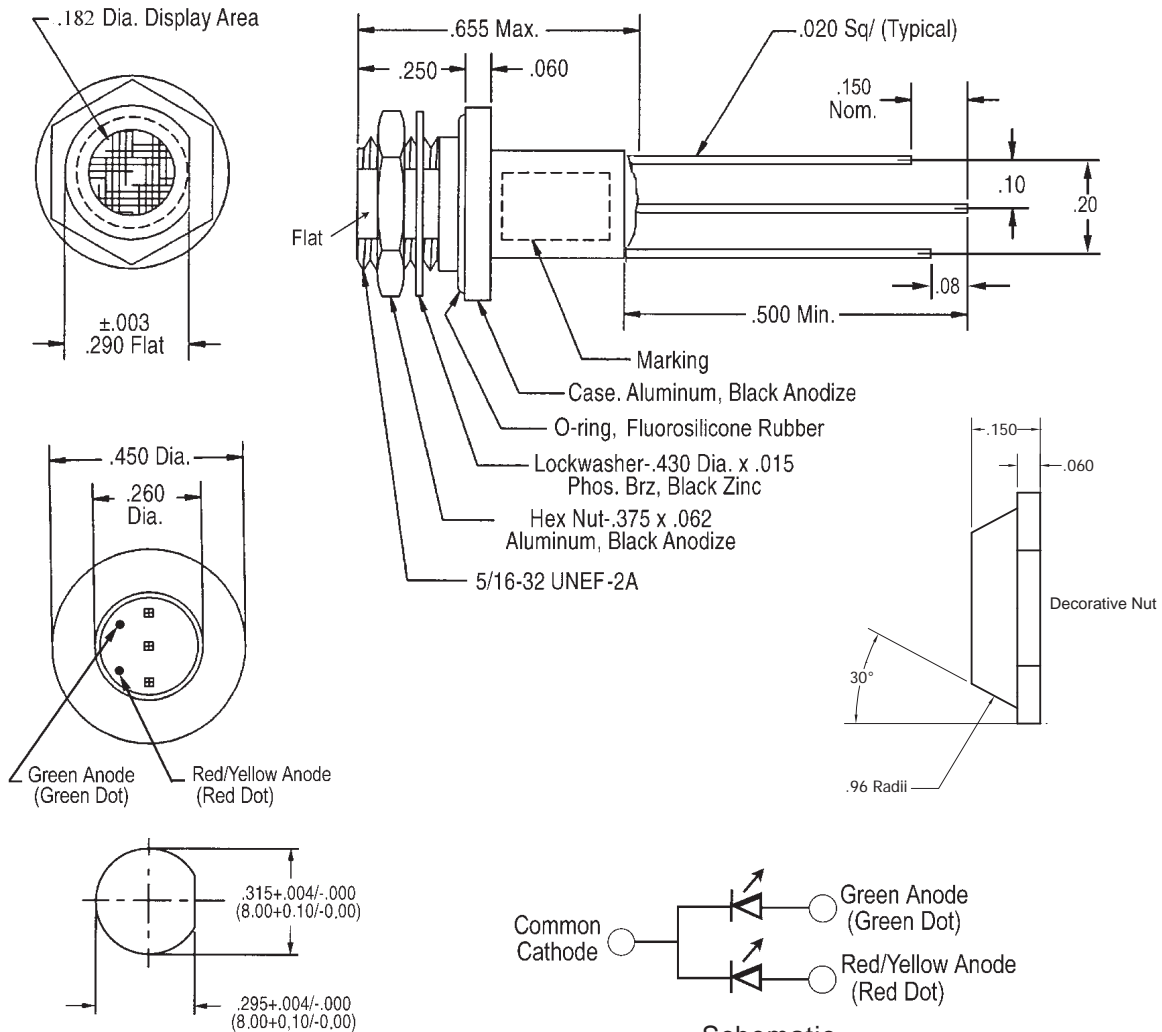

Recommended Mounting Hole

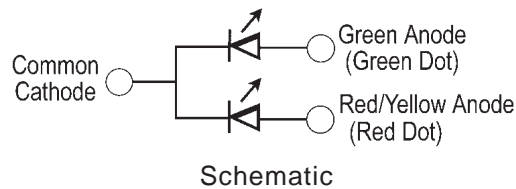

ML1635

NOTE: Dimensions in () are mm. Tolerances: Decimals: ± .010 (0.25)
Fractions: ± 1/64 Mounting Torque: 5-7 in. lbs.

This page consists of basic marketing information that is not defined as technical data under EAR Part 772.

LED INDICATOR REAR-MOUNT



Model ML1636

Developed for use as a status indicator, the ML1636 was designed to survive in the most severe environments. The small size and rugged package make it ideal for applications where status indication is critical to the operation of your equipment. The environmentally sealed case includes an O-ring panel seal that insures the integrity of your system. Comes complete with fluorosilicone O-ring and mounting hardware.

ML1636

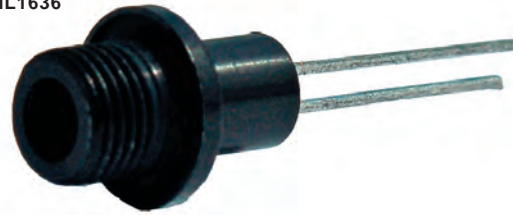

Standard Case

FEATURES

- Ideal for rugged environments
- Environmentally sealed
- Panel mount seal
- Colors: yellow, green & red
- Compact case design
- EMI screen option
- Decorative bezel

MECHANICAL SPECIFICATIONS

Case: Aluminum, black anodized, standard. Clear chromate case with EMI screen option.

Mounting: Rear-mount by 5/16"-32 nut and lockwasher

O-ring: Fluorosilicone rubber

ENVIRONMENTAL SPECIFICATIONS

Vibration: .06" D.A. or 20 Gs Peak, whichever is less, 10Hz to 2kHz, MIL STD 202, Method 204, Test Condition D

Shock: 100 Gs MIL STD 202, Method 213, Test Condition I

Moisture Resistance (Humidity): MIL STD 202, Method 106

Barometric Pressure (Reduced): 100,000 ft., MIL STD 202, Method 105, Test Condition D

Reliability: 3 x 10⁶ hours min. MTBF @ 25°C

Salt Atmosphere (Corrosion): MIL STD 202, Method 101, Test Condition B

ELECTRO-OPTICAL CHARACTERISTIC SPECIFICATIONS

Absolute Maximum Ratings @Temp = 25°C				
Color		Red	Yellow	Green
Forward Voltage (VDC) typical @ 10 mA		1.9	2.0	2.1
Peak Forward Current (mA) ①		90	60	90
DC Forward Current (mA) ②		30	30	25
Reverse Voltage (VDC) @ I _R = 100 μA		5	5	5
Power Dissipation (mW)		135	85	135
Luminous Intensity (mcd) typical @ I _F = 10 mA	Non-diffused	60	50	70
	Diffused	12	12	12
Dominant Wave Length (nm) typical		626	585	569
Viewing Angle	Non-diffused	35°	35°	24°
	Diffused	60°	60°	60°
Operating Temperature (°C)		-55 to +100	-55 to +100	-20 to +100
Storage Temperature (°C)		-55 to +100	-55 to +100	-50 to +100
Lead Soldering Temperature		260°C for 5 seconds		

Notes: ① Typical pulsing values: t_p ≤ 10 μsec, Duty cycle = 10%

② For red and green, derate linearly from 50°C @ 0.5 mA/°C. For yellow, derate linearly from 50°C @ 0.2 mA/°C

*These characteristics reflect the baseline model. Variations may imply a difference in luminous characteristics and/or operability features. Please contact the EDI Sales Department for more information.

This page consists of basic marketing information that is not defined as technical data under EAR Part 772.

LED INDICATOR REAR-MOUNT



ORDERING INFORMATION

When ordering, show model number first, followed by EMI screen, then LED color, lens style and terminal style. If this is a special part, a factory assigned modification number will be added at the end of the ordering number. Consult the factory for special configurations.

Example: Basic model with an EMI screen, with a yellow LED, diffused lens, and straight leads would be ML1636E-Y-D-ST.

ML1636E - Y - D - ST - ()

Standard factory options are designated by "-Sxxx"

Basic Model Number	EMI Screen	LED Color	Lens Type	Terminal Style	Internal Resistor
ML1636	() None	R Red	ND Non-diffused	ST Straight Leads	() - None
	E Screen	Y Yellow	D Diffused	LT Loop Terminals	5 - 5V
		G Green			

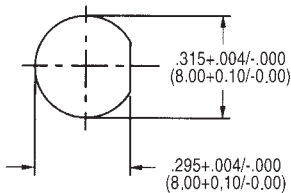
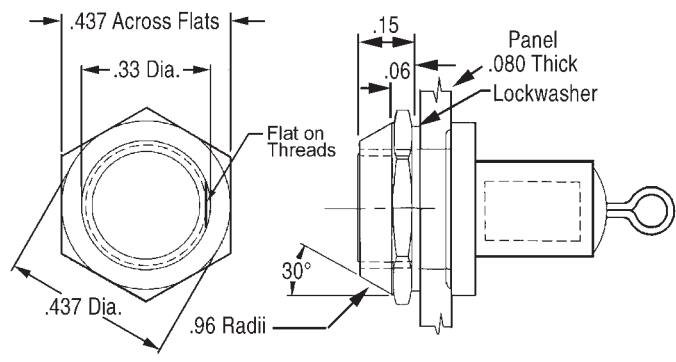
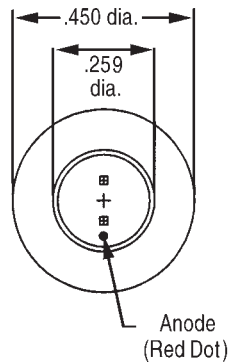
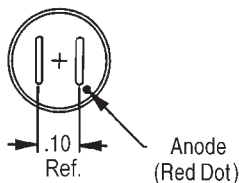
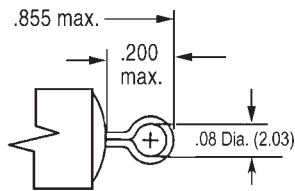
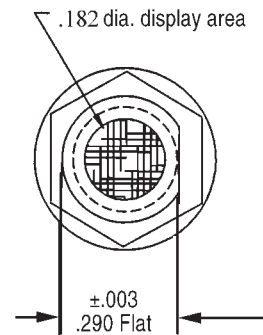

**Recommended
Mounting Hole**

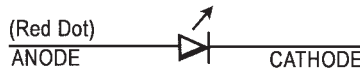

Schematic

ML1636

NOTE: Dimensions in () are mm. Tolerances: Decimals: ± .010 (0.25)
Fractions: ± 1/64 Mounting Torque: 5-7 in. lbs.

This page consists of basic marketing information that is not defined as technical data under EAR Part 772.

LED INDICATOR REAR-MOUNT BRIGHT



Model ML1636-U

Developed for use as a status indicator, the ML1636-U series was designed to survive in the most severe environments. The small size and rugged package make it ideal for applications where status indication is critical to the operation of your equipment. The environmentally sealed case includes an O-ring panel seal that insures the integrity of your system. Comes complete with fluorosilicone O-ring and mounting hardware.

ML1636-U

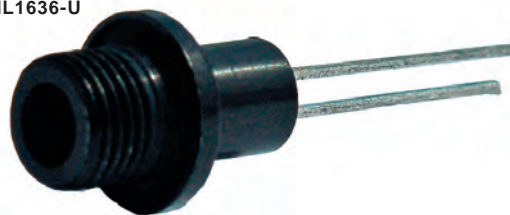

FEATURES

- Ideal for rugged environments
- Environmentally sealed
- Panel mount seal
- Compact case design
- Colors: green, red, amber, orange and red-orange
- EMI screen option
- Decorative bezel

MECHANICAL SPECIFICATIONS

Case: Aluminum, black anodized, standard. Clear chromate case with EMI screen option.

Mounting: Rear-mount by 5/16"-32 nut and lockwasher

O-ring: Fluorosilicone rubber

ENVIRONMENTAL SPECIFICATIONS

Vibration: .06" D.A. or 20 Gs Peak, whichever is less, 10Hz to 2kHz, MIL STD 202, Method 204, Test Condition D

Shock: 100 Gs MIL STD 202, Method 213, Test Condition I

Moisture Resistance (Humidity): MIL STD 202, Method 106

Barometric Pressure (Reduced): 100,000 ft., MIL STD 202, Method 105, Test Condition D

Reliability: 3 x 10⁶ hours min. MTBF @ 25°C

Salt Atmosphere (Corrosion): MIL STD 202, Method 101, Test Condition B

ELECTRO-OPTICAL CHARACTERISTIC SPECIFICATIONS

Absolute Maximum Ratings @Temp = 25°C					
Color	Red-Orange	Orange	Amber	Green	Red
Forward Voltage (VDC) typical @ 20 mA	1.9	2.0	2.0	3.2	1.9
DC Forward Current (mA) ①	50	50	50	30	50
Reverse Voltage (VDC) @ I _R = 100 μA	5	5	5	5	5
Junction Temperature	130°C	130°C	130°C	130°C	130°C
Luminous Intensity (mcd) typical @ I _F = 20 mA Non-diffused	600	600	600	1000	600
Dominant Wave Length (nm) typical @ I _F = 20 mA	615	605	590	526	626
Viewing Angle (2 Ø 1/2) typical	30°	30°	30°	30°	30°
Operating Temperature (°C)	-40 to +100	-40 to +100	-40 to +100	-40 to +80	-40 to +100
Storage Temperature (°C)	-40 to +100	-40 to +100	-40 to +100	-40 to +100	-40 to +100
Lead Soldering Temperature	260°C for 5 seconds				

Notes: ① Derate linearly from 50°; green @ 0.6 mA/°C; all other colors @ 0.7 mA/°C

This page consists of basic marketing information that is not defined as technical data under EAR Part 772.

LED INDICATOR REAR-MOUNT BRIGHT



ORDERING INFORMATION

When ordering, show model number first, followed by EMI screen, then LED color, lens style and terminal style. If this is a special part, a factory assigned modification number will be added at the end of the ordering number. Consult the factory for special configurations.

Example: Basic model with an EMI screen, with a red LED a non-diffused lens, and loop terminals would be ML1636E-UR-ND-LT.

ML1636E - UR - ND - LT - ()

Standard factory options are designated by "-Sxxx"

Basic Model Number	EMI Screen	LED Color	Lens Type	Terminal Style
ML1636	() None	UR Red	ND Non-diffused	WL Wire Leads
	E Screen	UG Green		LT Loop Terminals
		UA Amber		ST Straight Terminals
		UO Orange		
		UP Red-Orange		

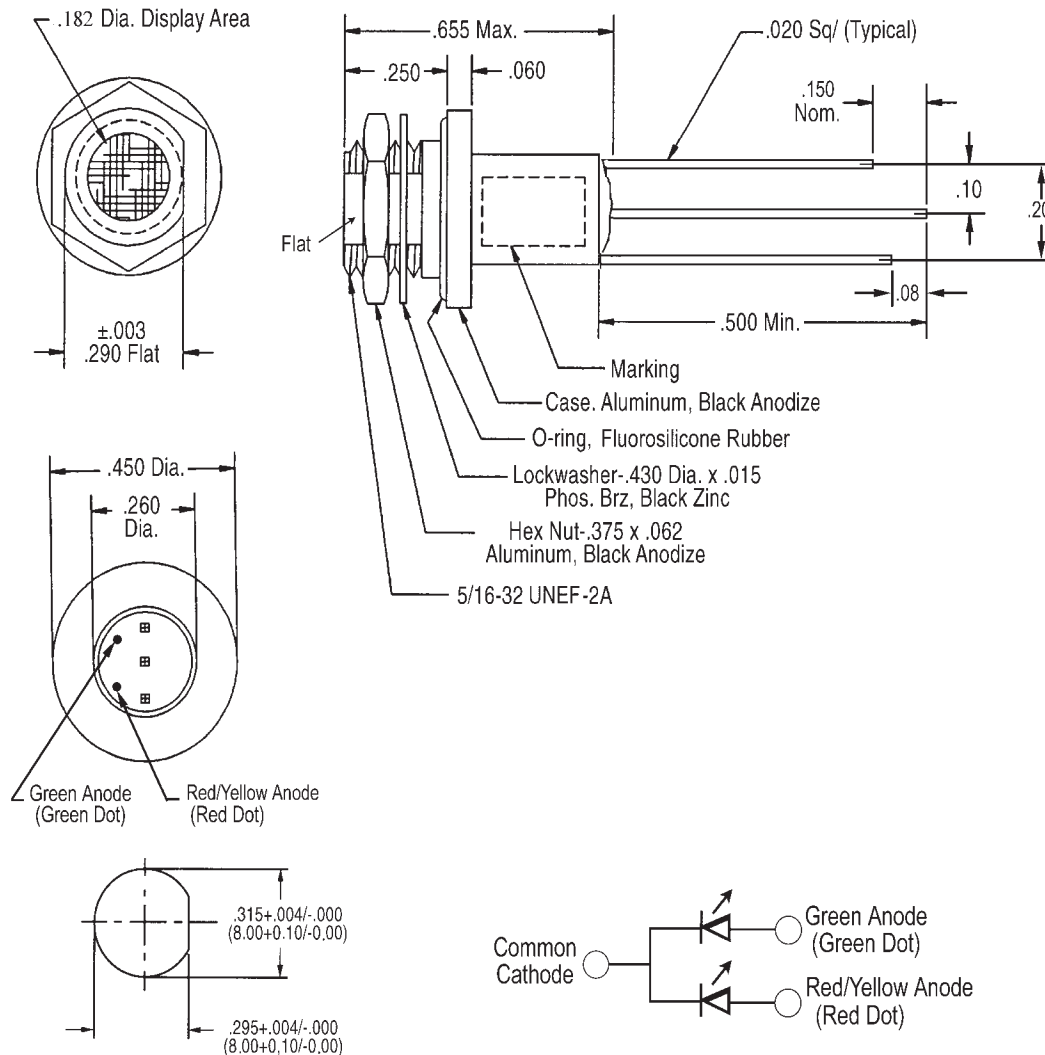

**Recommended
Mounting Hole**

Schematic

ML1636-U

NOTE: Dimensions in () are mm. Tolerances: Decimals: ± .010 (0.25)
Fractions: ± 1/64 Mounting Torque: 5-7 in. lbs.

This page consists of basic marketing information that is not defined as technical data under EAR Part 772.

LED INDICATOR

NVIS COMPATIBLE REAR-MOUNT



Model ML1638

The ML1638 status indicator was designed to meet the requirements of MIL-L-85762A and MIL-STD-3009. This solid-state LED indicator has an infrared blocking lens that is compatible with NVIS environments. It is a rear-mount indicator and comes complete with O-ring and mounting hardware.

ML1638

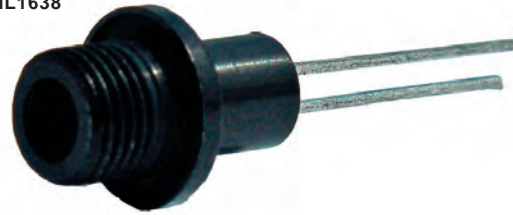

Standard Case

FEATURES

- Designed to meet MIL-L-85762A and MIL-STD-3009 lighting, aircraft, interior night vision imaging system (NVIS) compatible
- Environmentally sealed
- Panel mount seal
- Colors: red, yellow & green
- Compact case design
- Decorative bezel
- Optional EMI screen

MECHANICAL SPECIFICATIONS

Case: Aluminum, black anodized, standard. Clear chromate case with EMI screen option.

Mounting: Rear-mount by 5/16"-32 nut and lockwasher

O-ring: Fluorosilicone rubber

ENVIRONMENTAL SPECIFICATIONS

Vibration: .06" D.A. or 20 Gs Peak, whichever is less, 10Hz to 2kHz, MIL STD 202, Method 204, Test Condition D

Shock: 100 Gs MIL STD 202, Method 213, Test Condition I

Moisture Resistance (Humidity): MIL STD 202, Method 106

Barometric Pressure (Reduced): 100,000 ft., MIL STD 202, Method 105, Test Condition D

Reliability: 3 x 10⁶ hours min. MTBF @ 25°C

Salt Atmosphere (Corrosion): MIL STD 202, Method 101, Test Condition B

ELECTRO-OPTICAL CHARACTERISTIC SPECIFICATIONS

Absolute Maximum Ratings @Temp = 25°C			
Color	NVIS Red	NVIS Yellow	NVIS Green B
Forward Voltage (VDC) typical @ 20 mA	2.0	2.0	2.1
DC Forward Current (mA) ①	50	20	50
Reverse Voltage @ I _R = 100 µA	4	5	4
Power Dissipation (mW) typical	120	85	120
Luminous Intensity (mcd) typical @ I _F = 20 mA	200	3.0	20
	100	1.8	10
Chromaticity per MIL-L-85762A & MIL-STD-3009	NVIS Red	NVIS Yellow	NVIS Green B
Dominant Wave Length (nm) typical	605	585	558
NVIS Radiance per MIL-L-85762A & MIL-STD-3009	NR _B 1.4 x 10 ⁻⁷ @15 fL	NR _A 1.5 x 10 ⁻⁷ @15 fL NR _B 1.4 x 10 ⁻⁷ @15 fL	NR _A 1.7 x 10 ⁻¹⁰ @0.1 fL NR _B 1.7 x 10 ⁻¹⁰ @0.1 fL
Viewing Angle (2 Ø ^{1/2}) typical	30° x 50° 50°	32° 50°	32° 50°
Operating Temperature (°C)	-40 to +100	-55 to +100	-40 to +100
Storage Temperature (°C)	-55 to +100	-55 to +100	-55 to +100

Notes: ① DC Forward Current Derating. Yellow indicators, derate linearly from 50°C at 0.2 mA per °C. Green & Red indicators, derate linearly from 50°C at 0.5 mA per °C

*These characteristics reflect the baseline model. Variations may imply a difference in luminous characteristics and/or operability features. Please contact the EDI Sales Department for more information.

This page consists of basic marketing information that is not defined as technical data under EAR Part 772.

LED INDICATOR NVIS COMPATIBLE REAR-MOUNT



ORDERING INFORMATION

When ordering, show model number first, followed by EMI screen, then LED color, lens type, and terminal style. If this is a special part, a factory assigned modification number will be added at the end of the ordering number. Consult the factory for special configurations.

Example: Basic model, with an EMI screen, NVIS yellow LED, diffused lens, and straight leads would be ML1638E-Y-D-ST.

ML1638E - Y - D - ST - ()

Standard factory options are designated by "-Sxxx"

Basic Model Number	EMI Screen	LED Color	Lens Type	Terminal Style
ML1638	() None	R Red	ND Non-diffused	ST Straight Leads
	E Screen	Y Yellow	D Diffused	LT Loop Terminals
		G Green		

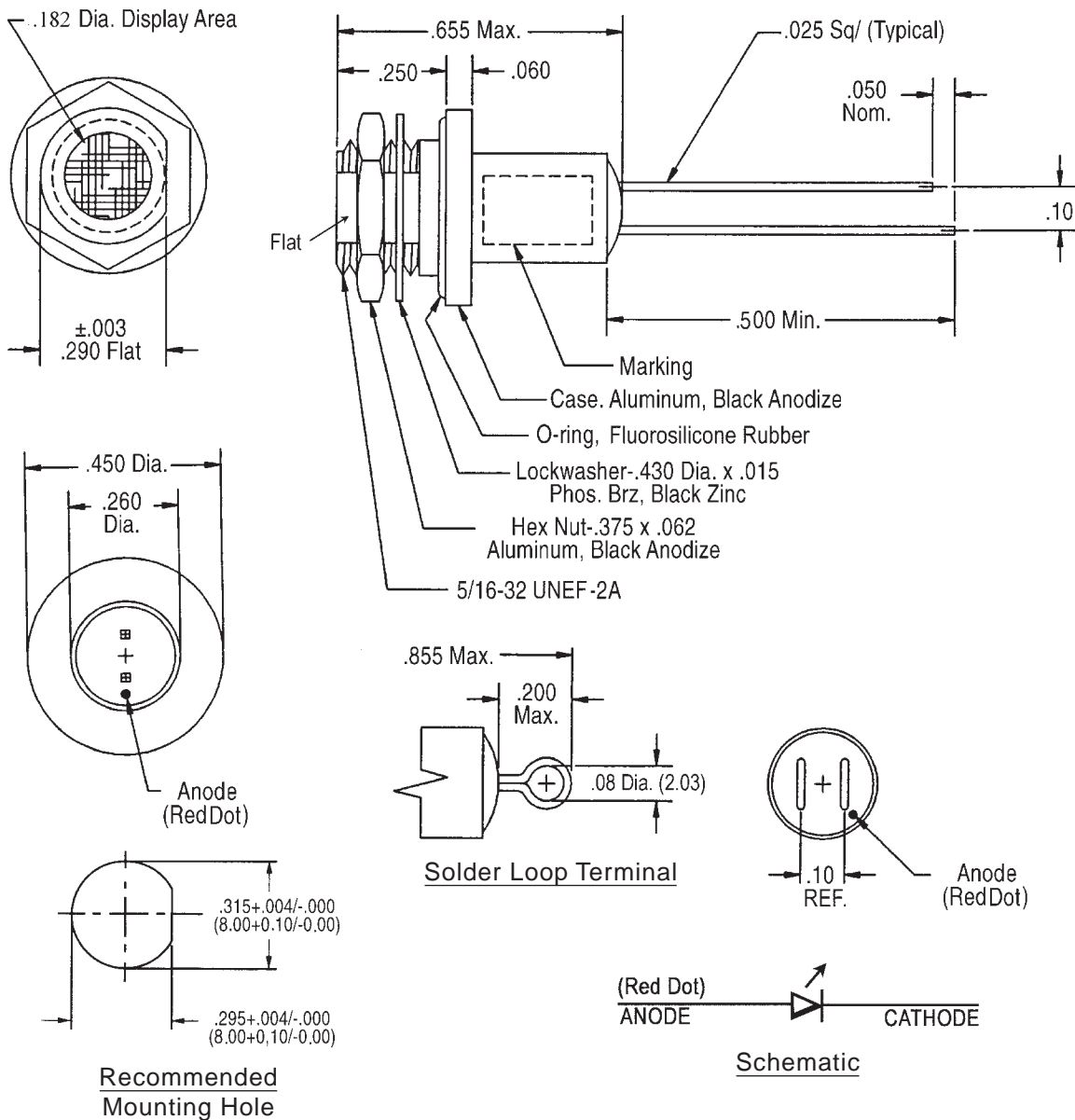

ML1638

NOTE: Dimensions in () are mm. Tolerances: Decimals: ± .010 (0.25)
Fractions: ± 1/64 Mounting Torque: 5-7 in. lbs.

This page consists of basic marketing information that is not defined as technical data under EAR Part 772.

LED INDICATOR

NVIS COMPATIBLE THREE LEAD BI-COLOR REAR-MOUNT



Model ML1638 Bi-Color 3-Leaded

The ML1638 Bi-Color status indicator was designed to meet the requirements of MIL-L-85762A and MIL-STD-3009. This solid-state LED indicator has an infrared blocking lens that is compatible with NVIS environments. It is a rear-mount indicator and comes complete with O-ring and mounting hardware.

ML1638E Bi-Color



Case with EMI Screen

FEATURES

- Designed to meet MIL-L-85762A and MIL-STD-3009 lighting, aircraft, interior night vision imaging system (NVIS) compatible
- Environmentally sealed
- Panel mount seal
- Colors: red/green
- Compact case design
- Decorative bezel
- Optional EMI screen

MECHANICAL SPECIFICATIONS

Case: Aluminum, black anodized, standard. Clear chromate case with EMI screen option.

Mounting: Rear-mount by 5/16"-32 nut and lockwasher

O-ring: Fluorosilicone rubber

ENVIRONMENTAL SPECIFICATIONS

Vibration: .06" D.A. or 20 Gs Peak, whichever is less, 10Hz to 2kHz, MIL STD 202, Method 204, Test Condition D

Shock: 100 Gs MIL STD 202, Method 213, Test Condition I

Moisture Resistance (Humidity): MIL STD 202, Method 106

Barometric Pressure (Reduced): 100,000 ft., MIL STD 202, Method 105, Test Condition D

Reliability: 3 x 10⁶ hours min. MTBF @ 25°C

Salt Atmosphere (Corrosion): MIL STD 202, Method 101, Test Condition B

ELECTRO-OPTICAL CHARACTERISTIC SPECIFICATIONS

Absolute Maximum Ratings @Temp = 25°C		
Color	NVIS Red	NVIS Green B
Forward Voltage (VDC) typical @ 20 mA	2.0	2.2
DC Forward Current (mA)	30	25
Reverse Voltage @ I _R = 100 µA	5	5
Power Dissipation (mW) typical ①	120	120
Luminous Intensity (mcd) typical @ I _F = 20 mA	12	1
Chromaticity per MIL-L-85762A & MIL-STD-3009	NVIS Red	NVIS Green B
Dominant Wave Length (nm) typical	600	558
NVIS Radiance per MIL-L-85762A & MIL-STD-3009	NR _B 1.4 x 10 ⁻⁷ @15 fL	NR _A 1.7 x 10 ⁻¹⁰ @0.1 fL NR _B 1.7 x 10 ⁻¹⁰ @0.1 fL
Viewing Angle (2 Ø 1/2) typical	Diffused	60°
Operating Temperature (°C)	-40 to +85	
Storage Temperature (°C)	-55 to +100	

Notes: ① Derate linearly from 25°C at ~1.2 mW per °C

This page consists of basic marketing information that is not defined as technical data under EAR Part 772.

LED INDICATOR

NVIS COMPATIBLE THREE LEAD BI-COLOR REAR-MOUNT



ORDERING INFORMATION

When ordering, show model number first, followed by EMI screen, LED color, common type, lens type, and terminal style. If this is a special part, a factory assigned modification number will be added at the end of the ordering number. Consult the factory for special configurations.

Example: Basic model with EMI screen, NVIS Red/Green Bi-Color LED, Anode Common, diffused lens, and straight leads would be ML1638E-R/G-CA-D-ST.

ML1638E - R/G - CA - D - ST - ()

Standard factory options are designated by "-Sxxx"

Basic Model Number	EMI Screen	LED Color	Common Lead	Lens Type	Terminal Style
ML1638	() None E Screen	R/G Red/Green	CA Anode CC Cathode	D Diffused	ST Straight Leads LT Loop Terminals

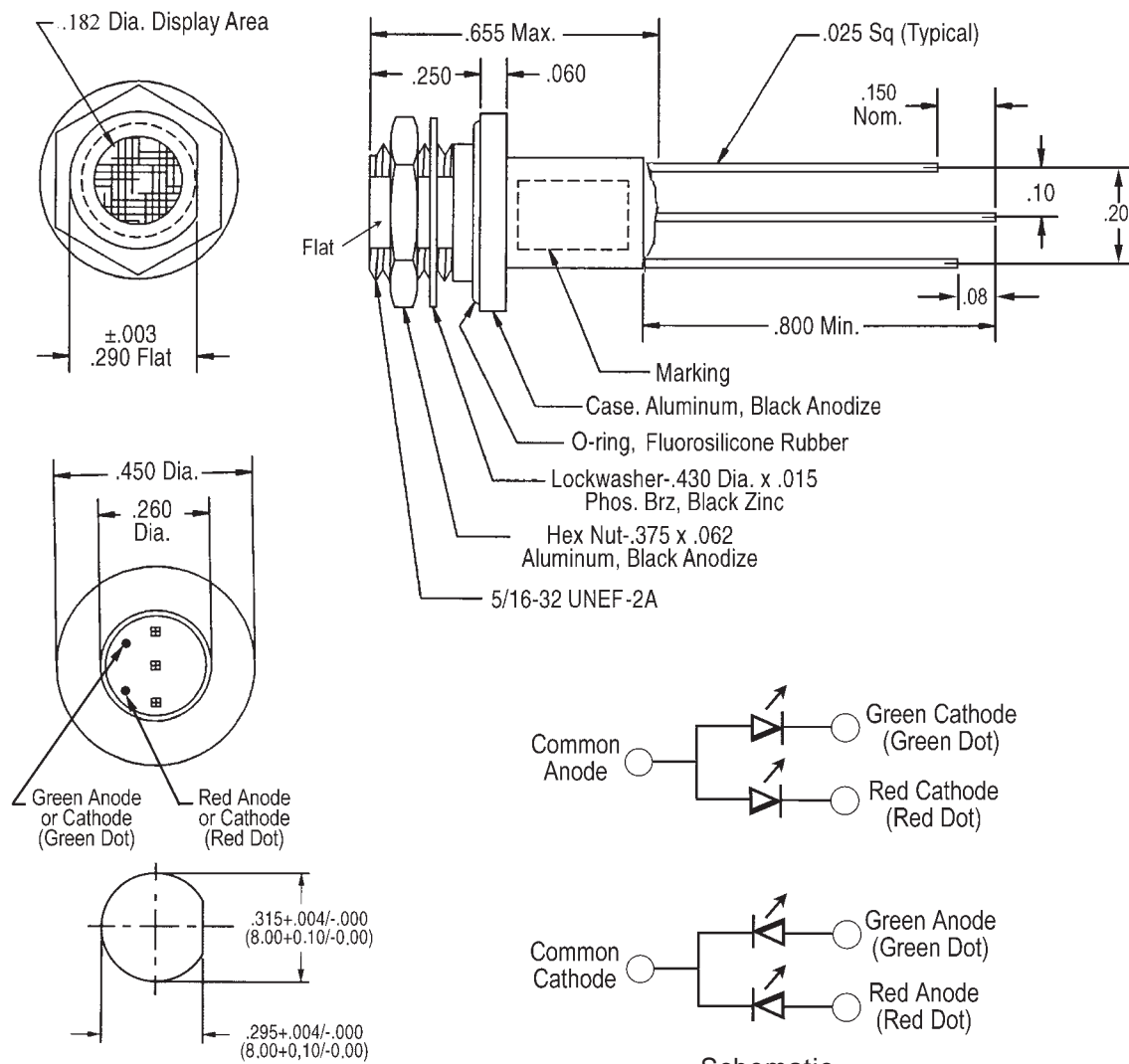

ML1638 Bi-Color

NOTE: Dimensions in () are mm. Tolerances: Decimals: ± .010 (0.25)
Fractions: ± 1/64 Mounting Torque: 5-7 in. lbs.

This page consists of basic marketing information that is not defined as technical data under EAR Part 772.

LED INDICATOR MIL-SPEC



ML1640 Series

Developed for use as a function indicator, this solid-state lamp with plain or filtered type lens, designed for sunlight viewing, is designed to meet the requirements of DESC drawing 85122. It is panel mountable with solderable leads and includes hardware. Available with anti-reflection lens coating.

ML1640



FEATURES

- Design meets DESC drawing 85122
- Environmentally sealed
- Optional EMI protection screen
- Colors: red, yellow & green
- Panel mount

MECHANICAL SPECIFICATIONS

- Bezel:** Aluminum, black anodized
Case: Aluminum, clear chromate
Mounting: Front panel by 5/16"-32 nut and lockwasher
Seal: Environmentally sealed with front panel PTFE ring seal

ENVIRONMENTAL SPECIFICATIONS

Units meet 100% screening in compliance with DESC 85122 and MIL-STD-750.

ELECTRO-OPTICAL CHARACTERISTIC SPECIFICATIONS

Absolute Maximum Ratings @Temp = 25°C			
Color	Red	Yellow	Green
Forward Voltage (VDC) Typical I_F @ 20 mA	1.9	2.1	2.2
Peak Forward Current (mA)	90	60	90
DC Forward Current (mA)	30	20	30
Reverse Voltage (VDC) @ $I_R = 100 \mu A$	5	5	5
Power Dissipation (mW)	135 ①	85 ②	135 ①
Luminous Intensity (mcd) typical	See chart	See chart	See chart
Dominant Wave Length (nm) typical	626	585	569
Operating Temperature (°C)	-55 to +100	-55 to +100	-20 to +100
Storage Temperature (°C)	-55 to +100	-55 to +100	-55 to +100
Lead Soldering Temperature	260°C for 5 seconds		

Notes: ① Derate at 1.8 mW/°C above +25°C Ambient
 ② Derate at 1.6 mW/°C above +50°C Ambient

Electrodynamics Model No. ③	DESC 85122 Dash No. ④	Type of Lens	Anti-reflect. Coating	EMI Screen	Outline Figure
ML1641-X011	R01, Y01, G01	Plano Convex	No	No	1
ML1644-X011	R02, Y02, G02	Plano Convex	No	No	2
ML1644-X111	R11, Y11, G11	Plano Convex	No	Yes	2a
ML1642-X011	R03, Y03, G03	Flat 30° View. Angle	No	No	3
ML1645-X011	R05, Y05, G05	Flat 30° View. Angle	No	No	4
ML1645-X021	R07, Y07, G07	Flat 30° View. Angle	Yes	No	4
ML1645-X121	R09, Y09, G09	Flat 30° View. Angle	Yes	Yes	4a
ML1643-X011	R04, Y04, G04	Flat 100° View. Angle	No	No	3
ML1646-X011	R06, Y06, G06	Flat 100° View. Angle	No	No	4
ML1646-X021	R08, Y08, G08	Flat 100° View. Angle	Yes	No	4
ML1646-X121	R10, Y10, G10	Flat 100° View. Angle	Yes	Yes	4a

Notes: ③ Substitute color X in Model No., i.e.: R=RED Y=YELLOW G=GREEN
 ④ Add 1A to end of DESC P/N's

DESC 85122 Dash No. ④	Min. Luminous Intensity @ Forward Current
R01, R02, R11	15 mcd @ 10 mA
Y01, Y02, Y11	12 mcd @ 10 mA
G01, G02, G11	12 mcd @ 20 mA
R03, R05, R07, R09	10 mcd @ 20 mA
Y03, Y05, Y07, Y09	5 mcd @ 15 mA
G03, G05, G07, G09	10 mcd @ 20 mA
R04, R06, R08, R10	1.0 mcd @ 15 mA
Y04, Y06, Y08, Y10	0.5 mcd @ 15 mA
G04, G06, G08, G10	1.0 mcd @ 20 mA

This page cleared by DoD/OSR for public release under 12-S-1675 on 04/23/2012.

LED INDICATOR MIL-SPEC



ORDERING INFORMATION

When ordering, show model number first, then LED color, EMI screen, coated lens, and the type of lead desired. If this is a special part, a factory assigned modification number will be added at the end of the ordering number. Consult the factory for special configurations.

Example: Basic model with red LED, EMI screen, uncoated lens, and straight lead would be model ML1644-R111.

ML1644 - R 1 1 1

Basic Model Number	LED Color	EMI Screen	Lens Coating	Terminal Style
ML1640	R Red	0 None	1 Uncoated	1 Straight Tin Lead
	Y Yellow	1 Screen	2 Anti-reflection Coating	2 Loop Terminals
	G Green			

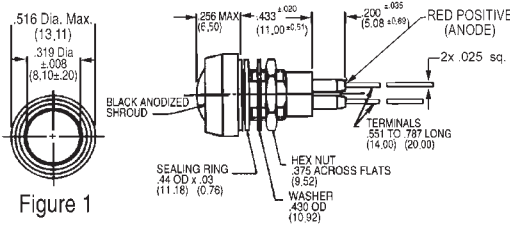

Figure 1

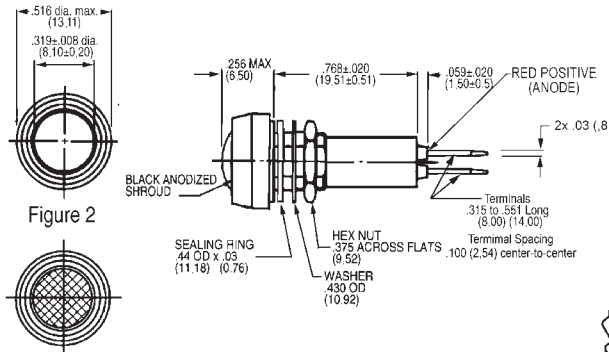
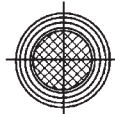

Figure 2



WITH EMI SCREEN

Figure 2a

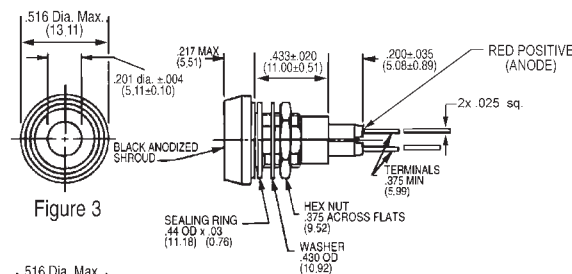
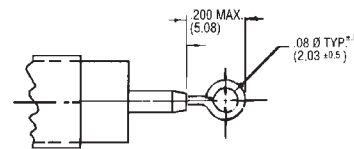

Figure 3



(-2) OPTIONAL LOOP TERMINAL

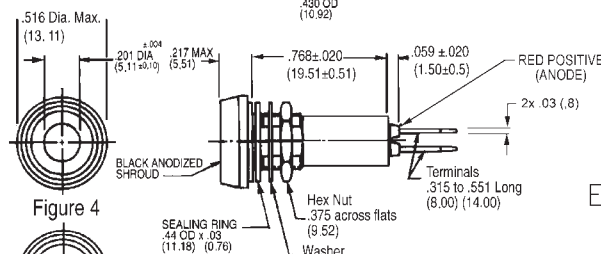
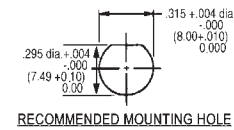

Figure 4



WITH EMI SCREEN
Figure 4a



RECOMMENDED MOUNTING HOLE

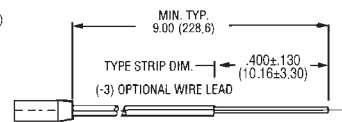

Schematic

ML1640 Series

NOTE: Dimensions in () are mm. Tolerances: Decimals: ± .010 (0.25)
Fractions: ± 1/64 Mounting Torque: 5-7 in. lbs.

This page cleared by DoD/OSR for public release under 12-S-1675 on 04/23/2012.

LIGHTING INDICATOR

MIL-SPEC NVIS COMPATIBLE



Model ML1662

The ML1662 status indicator was developed to meet the requirements of MIL-L-85762A and MIL-STD-3009. This solid-state lamp with infrared blocking lens is compatible with NVIS environments. It is a panel mount device with solderable leads and includes hardware.

FEATURES

- Designed to meet MIL-L-85762A and MIL-STD-3009 lighting, aircraft, interior night vision imaging system (NVIS) compatible
- Environmentally sealed
- Optional EMI protection screen
- Colors: yellow, green & red
- Front panel mount seal

MECHANICAL SPECIFICATIONS

Case: Aluminum, black anodized bezel with clear chromate body.

Mounting: Front panel by 5/16"-32 nut and lockwasher.

Seal: Environmentally sealed with front panel PTFE ring seal.

ML1662



ENVIRONMENTAL SPECIFICATIONS

Vibration: .06" D.A. or 20 Gs Peak, whichever is less, 10Hz to 2kHz, MIL STD 202, Method 204, Test Condition D

Shock: 100 Gs MIL STD 202, Method 213, Test Condition I

Moisture Resistance (Humidity): MIL STD 202, Method 106

Barometric Pressure (Reduced): 100,000 ft., MIL STD 202, Method 105, Test Condition D

Reliability: 3 x 10⁶ hours min. MTBF @ 25°C

Salt Atmosphere (Corrosion): MIL STD 202, Method 101, Test Condition B

ELECTRO-OPTICAL CHARACTERISTIC SPECIFICATIONS

Absolute Maximum Ratings @Temp = 25°C			
Color	NVIS Red	NVIS Yellow	NVIS Green B
Forward Voltage (VDC) typical @ 20 mA	2.0	2.0	2.1
DC Forward Current (mA) ①	50	20	50
Reverse Voltage @ I _R = 100 μA	4	5	4
Power Dissipation (mW)	120	85	120
Luminous Intensity (mcd) typical @ 20 mA diffused	100	1.8	10
Chromaticity per MIL-L-85762A & MIL-STD-3009	NVIS Red	NVIS Yellow	NVIS Green B
NVIS Radiance per MIL-L-85762A & MIL-STD-3009	NR _B 1.4 x 10 ⁻⁷ @15 fL	NR _A 1.5 x 10 ⁻⁷ @15 fL NR _B 1.4 x 10 ⁻⁷ @15 fL	NR _A 1.7 x 10 ⁻¹⁰ @0.1 fL NR _B 1.7 x 10 ⁻¹⁰ @0.1 fL
Dominant Wave Length (nm) typical	605	585	558
Viewing Angle (2 Ø ^{1/2}) diffused	50°	50°	50°
Operating Temperature (°C)	-40 to +100	-55 to +100	-40 to +100
Storage Temperature (°C)	-55 to +100	-55 to +100	-55 to +100

Notes: ① DC Forward Current Derating. Yellow indicators, derate linearly from 50°C at 0.2 mA per °C. Green & Red indicators, derate linearly from 50°C at 0.5 mA per °C

This page consists of basic marketing information that is not defined as technical data under EAR Part 772.

LIGHTING INDICATOR

MIL-SPEC NVIS COMPATIBLE



ORDERING INFORMATION

When ordering, show model number first, then LED color, EMI screen, body finish, and the terminal style desired. If this is a special part, a factory assigned modification number will be added at the end of the ordering number. Consult the factory for special configurations.

Example: Basic model with green LED, EMI screen, a clear chromate body finish, and a tin lead terminal finish would be model ML1662-G121.

ML1662 - G - 1 - 2 - 1

Basic Model Number	LED Color	EMI Screen	Body Finish Color	Terminal Style
ML1662	R Red	0 None	2 Clear Chromate	1 Straight Tin Lead
	Y Yellow	1 Screen		2 Loop Terminals
	G Green			

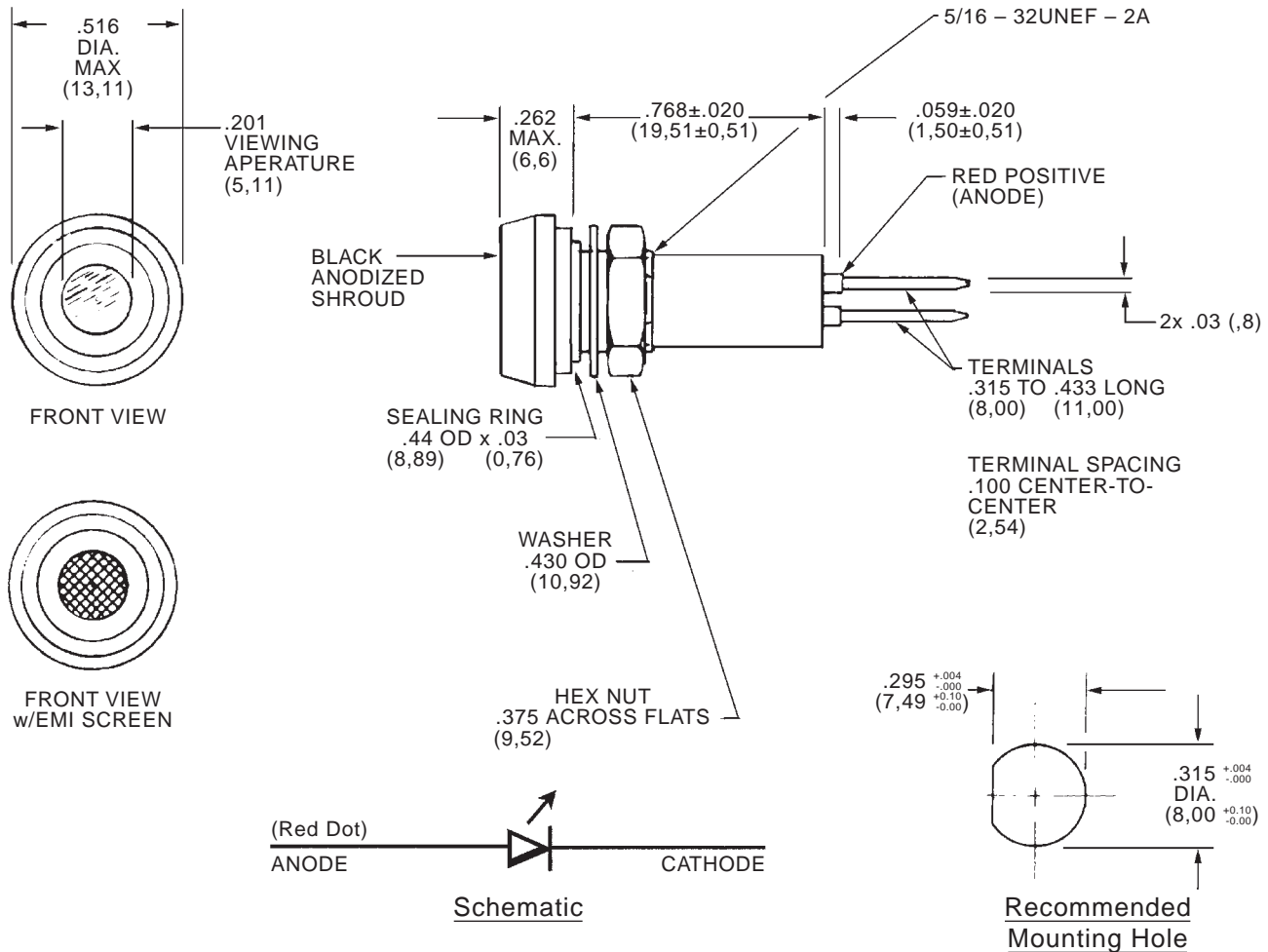

ML1662

NOTE: Dimensions in () are mm. Tolerances: Decimals: ± .010 (0.25)
 Fractions: ± 1/64 Mounting Torque: 5-7 in. lbs.

This page consists of basic marketing information that is not defined as technical data under EAR Part 772.

LED INDICATOR SOLID FRONT WATERTIGHT PANEL SEAL



Model ML2030

Designed for use where a watertight panel seal is required for system performance. Can be used as a function indicator on aircraft avionics systems, test equipment, medical equipment, machine tools, and wherever severe environmental conditions are present.

FEATURES

- O-ring panel seal
- Dual finish case
- Low power use
- Performs in severe environments
- Rugged construction

MECHANICAL SPECIFICATIONS

Case: Aluminum, black anodized front bezel with conductive clear chromate body.

Mounting: Front panel mount with 5/16"-32 nut and lock washer.

Seal: Environmentally sealed case. MIL-DTL-3661, Para. 4.6.11.1

O-ring: Fluorosilicone rubber

ML2030E

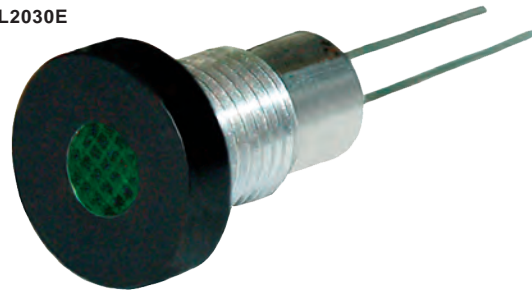

ENVIRONMENTAL SPECIFICATIONS

Vibration: .06" D.A. or 20 Gs Peak, whichever is less, 10Hz to 2kHz, MIL STD 202, Method 204, Test Condition D

Shock: 100 Gs MIL STD 202, Method 213, Test Condition I

Moisture Resistance (Humidity): MIL STD 202, Method 106

Barometric Pressure (Reduced): 100,000 ft., MIL STD 202, Method 105, Test Condition D

Reliability: 3 x 10⁶ hours min. MTBF @ 25°C

Salt Atmosphere (Corrosion): MIL STD 202, Method 101, Test Condition B

ELECTRO-OPTICAL CHARACTERISTIC SPECIFICATIONS

Absolute Maximum Ratings @Temp = 25°C			
Color	Red	Yellow	Green
Forward Voltage (VDC)	1.9	2.0	2.1
DC Forward Current (mA DC) ①	30	20	30
Reverse Voltage (VDC) @ I _R = 100 μA	5	5	5
Power Dissipation (mW)	135	85	135
Luminous Intensity (mcd) typical @ I _F = 10 mA	Non-diffused	60	50
	Diffused	11	12
Dominant Wave Length (nm) typical	626	585	569
Viewing Angle (2 Ø ^{1/2}) typical	Non-diffused	35°	24°
	Diffused	60°	60°
Operating Temperature (°C)	-55 to +100	-55 to +100	-20 to +100
Storage Temperature (°C)	-55 to +100	-55 to +100	-55 to +100
Lead Soldering Temperature	260°C for 5 seconds		

Notes: ① For red and green, derate linearly from 50°C @ 0.5 mA/°C. For yellow derate linearly from 50°C @ 0.2 mA/°C

This page consists of basic marketing information that is not defined as technical data under EAR Part 772.

LED INDICATOR SOLID FRONT WATERTIGHT PANEL SEAL



ORDERING INFORMATION

When ordering, show basic part number first, LED color, lens type, and terminal style. If this part requires customization, a special factory assigned modification number will be assigned to the end of the ordering number. Consult the factory for special configurations.

Example: Basic model with EMI screen, a red LED, a diffused lens, and looped terminals would be ML2030E-R-D-LT.

ML2030E - R - D - LT - ()

Standard factory options are designated by "-Sxxx"

Basic Model Number	EMI Screen	LED Color	Lens Type	Terminal Style
ML2030		R Red	ND Non-diffused	ST Straight Leads
	E Screen	Y Yellow	D Diffused	LT Loop Terminals
		G Green		

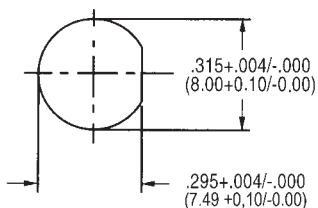
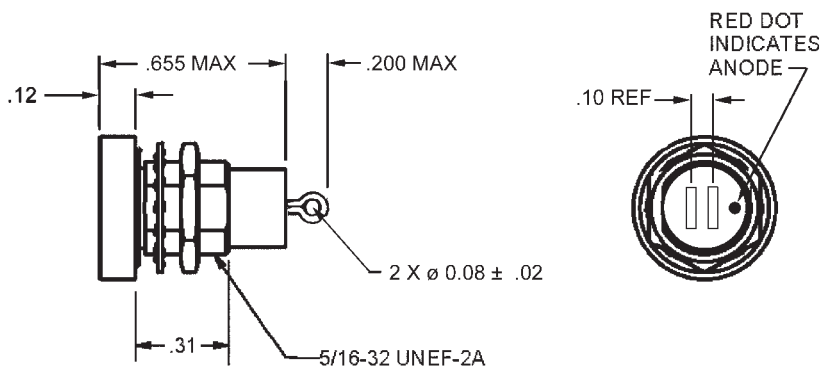
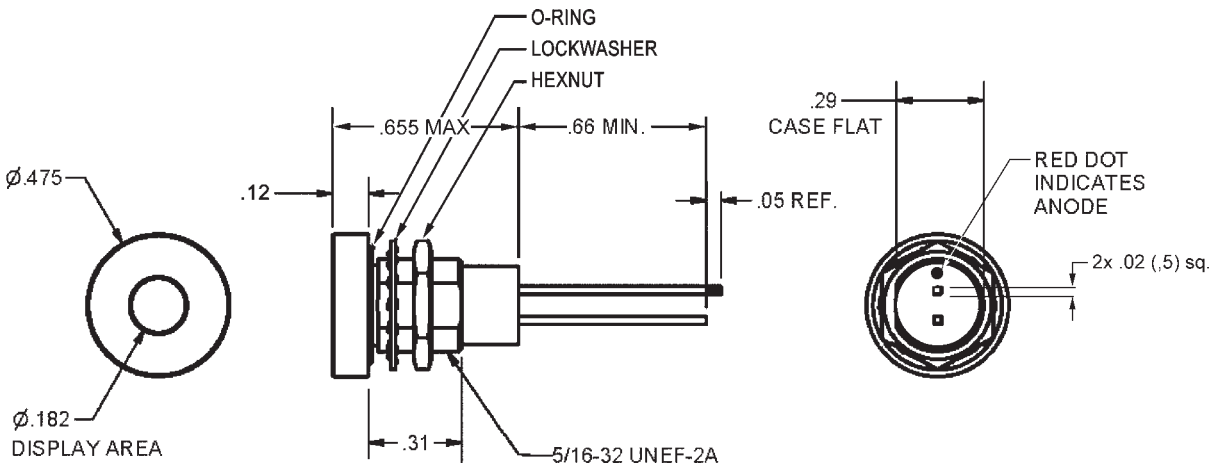

**Recommended
Mounting Hole**

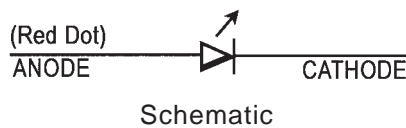

NOTE:
Ø .475 AND FRONT SURFACE OF FLANGE IS BLACK ANODIZED.
ALL OTHER SURFACES ARE CLEAR CHROMATE.

ML2030

NOTE: Dimensions in () are mm. Tolerances: Decimals: ± .010 (0.25)
Fractions: ± 1/64 Mounting Torque: 10-12 in. lbs.

This page consists of basic marketing information that is not defined as technical data under EAR Part 772.

LED INDICATOR

WATERTIGHT PANEL SEAL TRI-COLOR



Model ML2031

Designed for use where a watertight panel seal is required for system performance. Can be used as a function indicator on aircraft avionics systems, test equipment, medical equipment, machine tools and wherever severe environmental conditions are present.

FEATURES

- O-ring panel seal
- Dual-finish case
- Performs in severe environments
- Low power use
- Rugged construction
- Colors: red, green and blue
- Multiple status indication within a single package
- Wide viewing angle

MECHANICAL SPECIFICATIONS

Case: Aluminum, black anodized front bezel with conductive clear chromate body

Mounting: Front panel mount with 5/16"-32 nut and lock washer

Seal: Environmentally sealed case. MIL-DTL-3661, Para. 4.6.11.1

O-Ring: Fluorosilicone rubber

ML2031

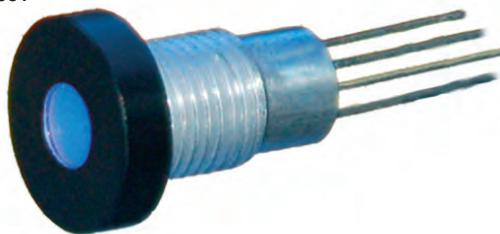

ENVIRONMENTAL SPECIFICATIONS

Vibration: .06" D.A. or 20 Gs Peak, whichever is less, 10Hz to 2kHz, MIL STD 202, Method 204, Test Condition D

Shock: 100 Gs MIL STD 202, Method 213, Test Condition I

Moisture Resistance (Humidity): MIL STD 202, Method 106

Barometric Pressure (Reduced): 100,000 ft., MIL STD 202, Method 105, Test Condition D

Reliability: 3 x 10⁶ hours min. MTBF @ 25°C

Salt Atmosphere (Corrosion): MIL STD 202, Method 101, Test Condition B

ELECTRO-OPTICAL CHARACTERISTIC SPECIFICATIONS

Absolute Maximum Ratings @Temp = 25°C			
Color	Red	Green	Blue
Forward Voltage (VDC) typical @ 20 mA	1.9	3.3	3.3
DC Forward Current (mA DC) ①	30	25	30
Reverse Voltage (VDC) @ I _R = 100 μA	5	5	5
Power Dissipation (mW)	75	102	120
Luminous Intensity (mcd) typical @ I _F = 20 mA DC	60	125	85
Dominant Wave Length (nm) typical	630	525	465
Viewing Angle (2 Ø ^{1/2}) typical	130°		
Operating Temperature (°C)	-40 to +85		
Storage Temperature (°C)	-55 to +100		
Lead Soldering Temperature	260°C for 5 seconds		

Notes: ① Derate linearly from 25°C @ -0.4 mA/°C.

This page consists of basic marketing information that is not defined as technical data under EAR Part 772.

LED INDICATOR WATERTIGHT PANEL SEAL TRI-COLOR



ORDERING INFORMATION

When ordering, show model number first, followed by EMI screen, then LED colors, lens style, and terminal style. If this part requires customization, a special factory assigned modification number will be added at the end of the ordering number. Consult the factory for special configurations.

Example: Basic model with an EMI screen, red/green/blue LED, a diffused lens and straight leads would be ML2031E-RGB-D-ST.

ML2031E - RGB - D - ST - ()

Standard factory options are designated by "-Sxxx"

Basic Model Number	EMI Screen	LED Color	Lens Type	Terminal Style
ML2031	() None E Screen	RGB Red, Green, Blue	D Diffused	ST Straight Leads

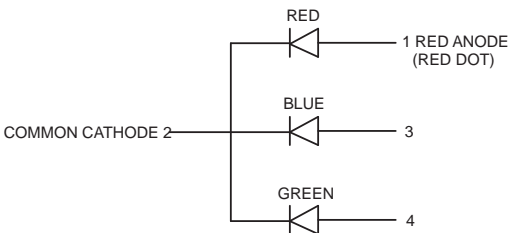
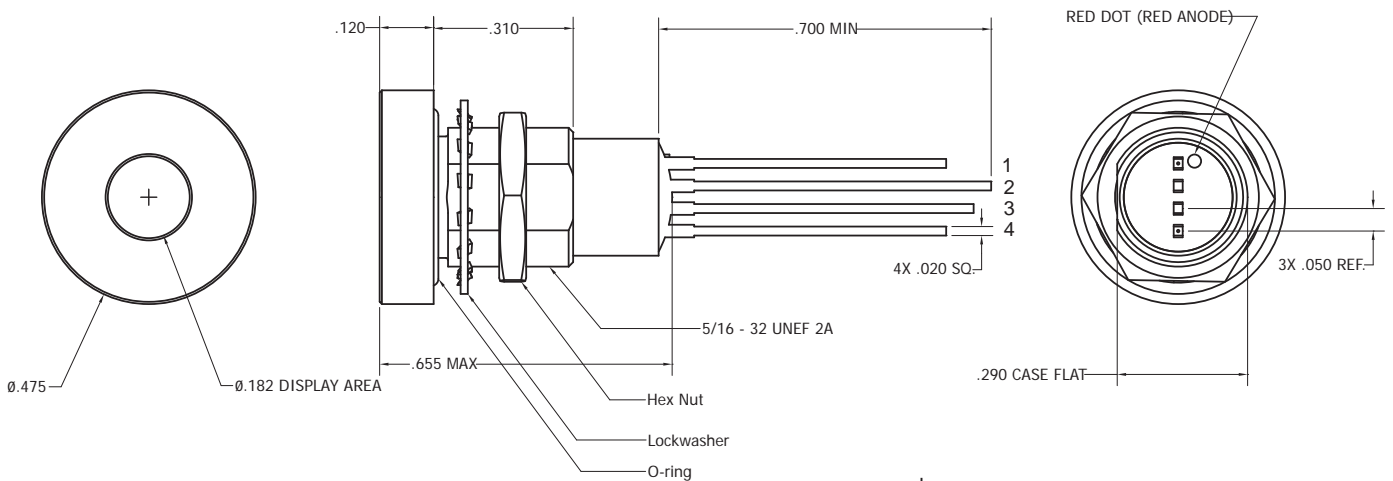

Schematic

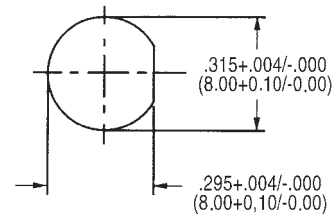

Recommended Mounting Hole

ML2031

LED INDICATORS

NOTE: Dimensions in () are mm. Tolerances: Decimals: $\pm .010$ (0.25)
Fractions: $\pm 1/64$ Mounting Torque: 10-12 in. lbs.

This page consists of basic marketing information that is not defined as technical data under EAR Part 772.

LED INDICATOR

NVIS COMPATIBLE TIGHT PANEL SEAL



Model ML2038

The ML2038E status indicator is designed to meet the requirements of MIL-L-85762A and MIL-STD-3009. This solid-state LED indicator has an infrared blocking lens that is compatible with NVIS environments. It is a rear-mount indicator and comes complete with O-ring and mounting hardware.

ML2038E

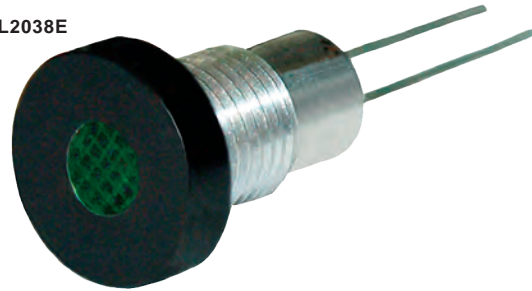

FEATURES

- Designed to meet MIL-L-85762A and MIL-STD-3009 lighting, aircraft, interior night vision imaging system (NVIS) compatible
- Performs in severe environments
- O-ring panel seal
- Dual-finish case
- Compact case design
- Rugged construction

MECHANICAL SPECIFICATIONS

Case: Aluminum, black anodized, front bezel with conductive clear chromate body.

Mounting: Front Panel mount with 5/16"-32 nut and lockwasher

Seal: MIL-DTL-3661C, paragraph 4.6.11.1

O-ring: Fluorosilicone rubber

ENVIRONMENTAL SPECIFICATIONS

Vibration: .06" D.A. or 20 Gs Peak, whichever is less, 10Hz to 2kHz, MIL STD 202, Method 204, Test Condition D

Shock: 100 Gs MIL STD 202, Method 213, Test Condition I

Moisture Resistance (Humidity): MIL STD 202, Method 106

Barometric Pressure (Reduced): 100,000 ft., MIL STD 202, Method 105, Test Condition D

Reliability: 3 x 10⁶ hours min. MTBF @ 25°C

Salt Atmosphere (Corrosion): MIL STD 202, Method 101, Test Condition B

ELECTRO-OPTICAL CHARACTERISTIC SPECIFICATIONS

Absolute Maximum Ratings @Temp = 25°C			
Color	NVIS Red	NVIS Yellow	NVIS Green B
Forward Voltage (VDC) typical @ 20 mA	2.0	2.0	2.1
DC Forward Current (mA) ①	50	20	50
Reverse Voltage @ I _R = 100 μA	4	5	4
Power Dissipation (mW) typical	120	85	120
Luminous Intensity (mcd) typical @ I _F = 20 mA	200	3.0	20
	N/A	N/A	10
Chromaticity per MIL-L-85762A & MIL-STD-3009	NVIS Red	NVIS Yellow	NVIS Green B
Dominant Wave Length (nm) typical	605	585	558
NVIS Radiance per MIL-L-85762A & MIL-STD-3009	NR _B 1.4 x 10 ⁻⁷ @15 fL	NR _A 1.5 x 10 ⁻⁷ @15 fL NR _B 1.4 x 10 ⁻⁷ @15 fL	NR _A 1.7 x 10 ⁻¹⁰ @0.1 fL NR _B 1.7 x 10 ⁻¹⁰ @0.1 fL
Viewing Angle (2 Ø ^{1/2}) typical	Non-diffused Diffused*	30° x 50° N/A	32° 50°
Operating Temperature (°C)	-40 to +100	-55 to +100	-40 to +100
Storage Temperature (°C)	-55 to +100	-55 to +100	-55 to +100

Notes: ① DC Forward Current Derating. Yellow indicators, derate linearly from 50°C at 0.2 mA per °C. Green & Red indicators, derate linearly from 50°C at 0.5 mA per °C

* Only available for NVIS Green B

This page consists of basic marketing information that is not defined as technical data under EAR Part 772.

LED INDICATOR NVIS COMPATIBLE TIGHT PANEL SEAL



ORDERING INFORMATION

When ordering, show model number first, followed by EMI screen, then LED color, lens type, and terminal style. If this is a special part, a factory assigned modification number will be added at the end of the ordering number. Consult the factory for special configurations.

Example: Basic model, with an EMI screen, NVIS yellow LED, non-diffused lens, and straight leads would be ML2038E-Y-ND-ST.

ML2038E - Y - ND - ST - ()

Standard factory options are designated by "-Sxxx"

Basic Model Number	EMI Screen	LED Color	Lens Type	Terminal Style
ML2038		R Red	ND Non-diffused	ST Straight Leads
	E Screen	Y Yellow	D Diffused	LT Loop Terminals
		G Green		

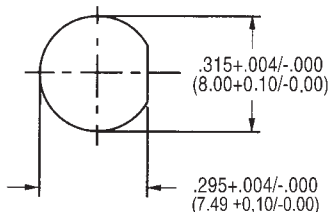
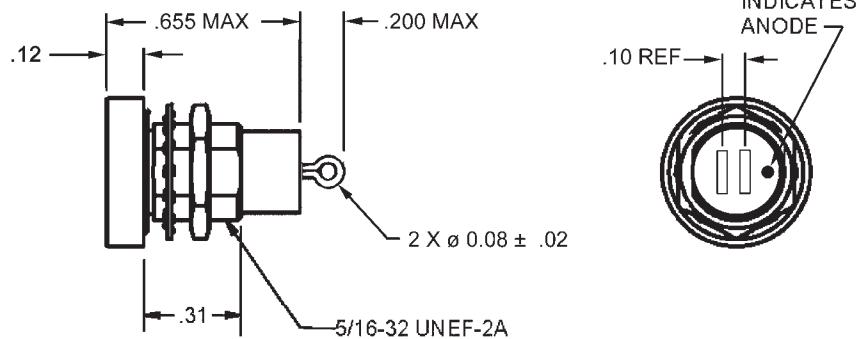
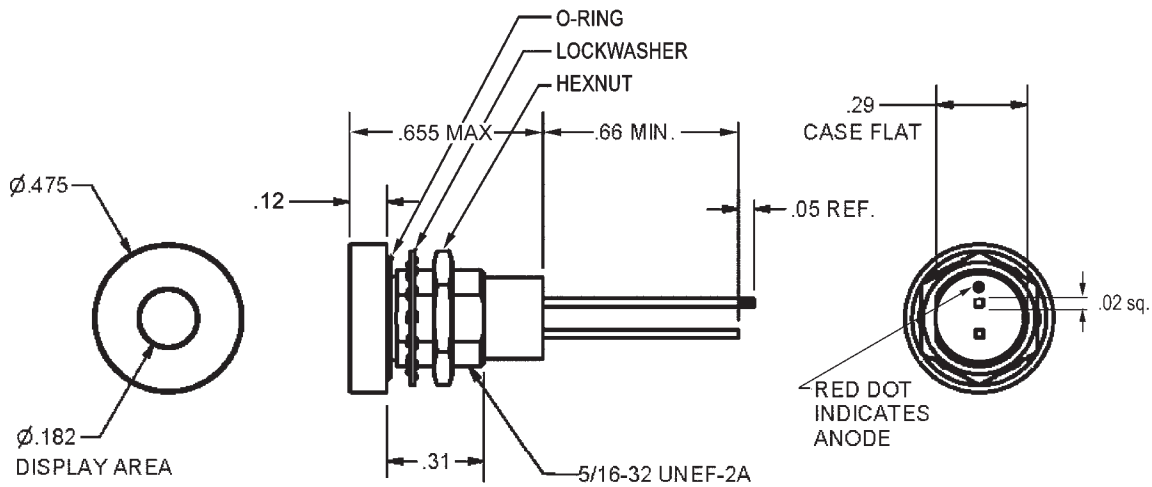

Recommended Mounting Hole

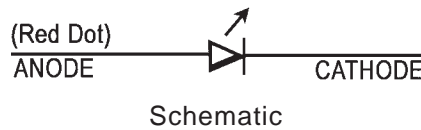

NOTE:
Ø .475 AND FRONT SURFACE OF FLANGE IS BLACK ANODIZED.
ALL OTHER SURFACES ARE CLEAR CHROMATE.

ML2038

NOTE: Dimensions in () are mm. Tolerances: Decimals: ± .010 (0.25)
Fractions: ± 1/64 Mounting Torque: 10-12 in. lbs.

This page consists of basic marketing information that is not defined as technical data under EAR Part 772.

LED INDICATOR VARIABLE VOLTAGE



Model ML4036

The ML4036 operates across a wide voltage range without the need for any external resistors. Nearly constant light intensity is maintained across the operating voltage range. The LED package is environmentally sealed and it comes complete with a fluorosilicone O-ring and mounting hardware.

FEATURES

- Ideal for rugged environments
- Environmentally sealed
- Panel mount seal
- Colors: yellow, green & red
- Decorative bezel
- Wide operating voltage

MECHANICAL SPECIFICATIONS

Case: Aluminum, black anodized, standard.

Mounting: Rear-mount by 5/16"-32 nut and lockwasher

O-ring: Fluorosilicone rubber

ML4036



ENVIRONMENTAL SPECIFICATIONS

Vibration: .06" D.A. or 20 Gs Peak, whichever is less, 10Hz to 2kHz, MIL STD 202, Method 204, Test Condition D

Shock: 100 Gs MIL STD 202, Method 213, Test Condition I

Moisture Resistance (Humidity): MIL STD 202, Method 106

Dielectric Withstanding Voltage: MIL-STD-202, Method 301, 1000VAC

Barometric Pressure (Reduced): 100,000 ft., MIL STD 202, Method 105, Test Condition D

Reliability: 3 x 10⁶ hours min. MTBF @ 25°C

Salt Atmosphere (Corrosion): MIL STD 202, Method 101, Test Condition B

ELECTRO-OPTICAL CHARACTERISTIC SPECIFICATIONS

Absolute Maximum Ratings @Temp = 25°C			
Color	Red	Yellow	Green
Operating Voltage (VDC) min.		5.0	
Operating Voltage (VDC) max.		28	
DC Forward Current (mA)		12	
Reverse Voltage (VDC) @ I _R = 100 µA		5	
Power Dissipation (mW)		300	
Luminous Intensity (mcd) typical @ V _F = 10 VDC	Non-diffused	500	100
	Diffused	125	20
Dominant Wave Length (nm) typical	640	588	558
Viewing Angle	Non-diffused	30°	
	Diffused	60°	
Operating Temperature (°C)		-40 to +85	
Storage Temperature (°C)		-40 to +85	
Lead Soldering Temperature		260°C for 3 seconds	

This page consists of basic marketing information that is not defined as technical data under EAR Part 772.

LED INDICATOR VARIABLE VOLTAGE



ORDERING INFORMATION

When ordering, show model number first, followed by LED color, then lens style, and terminal style. If this is a special part, a factory assigned modification number will be added at the end of the ordering number. Consult the factory for special configurations.

Example: Basic model with a yellow LED, a diffused lens, and straight leads would be ML4036-Y-D-ST.

ML4036 - Y - D - ST - ()

Standard factory options are designated by "-Sxxx"

Basic Model Number	LED Color	Lens Type	Terminal Style
ML4036	R Red	ND Non-diffused	ST Straight Leads
	Y Yellow	D Diffused	LT Loop Terminals
	G Green		

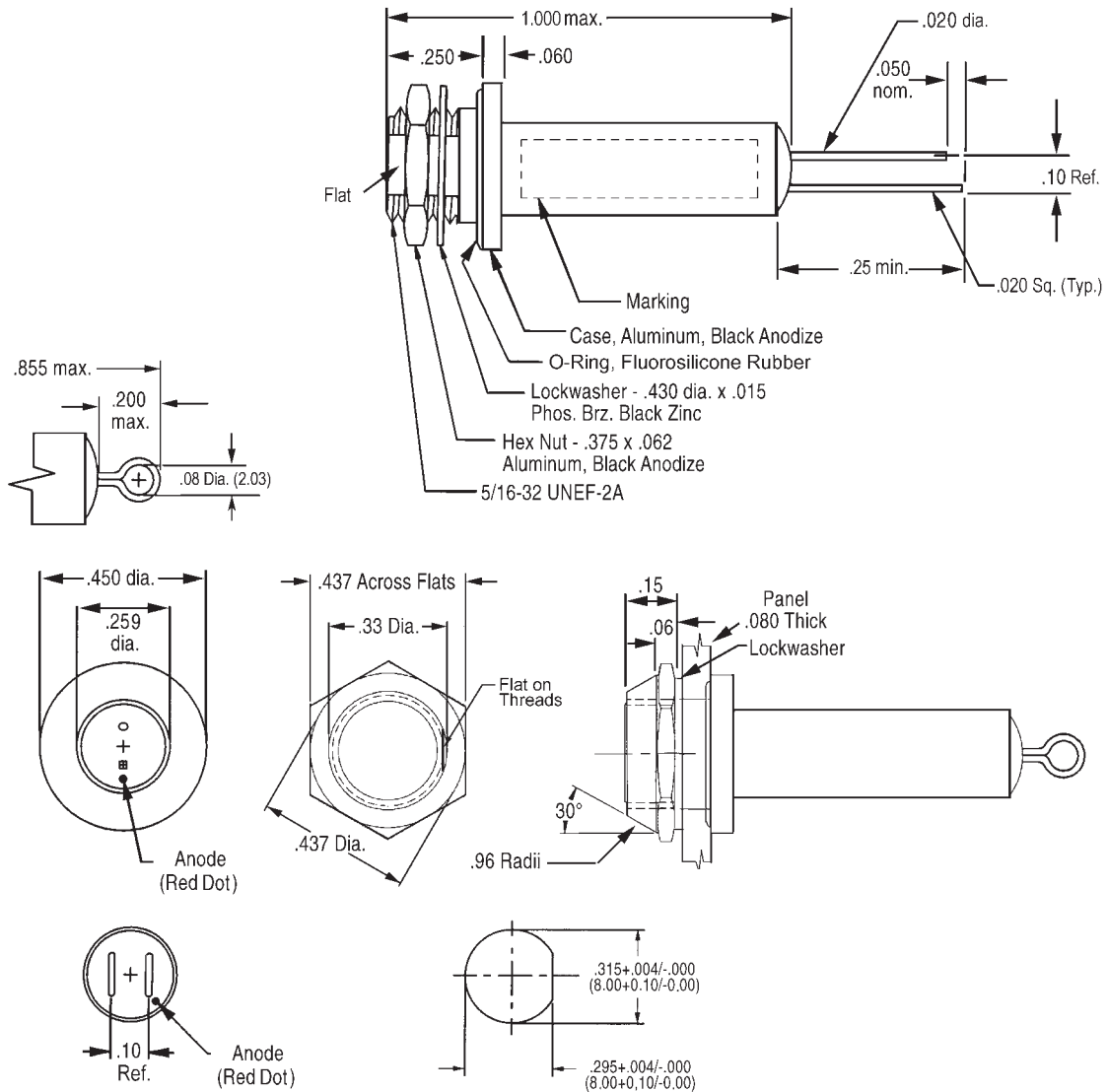

Recommended Mounting Hole

ML4036

NOTE: Dimensions in () are mm. Tolerances: Decimals: ± .010 (0.25)
Fractions: ± 1/64 Mounting Torque: 5-7 in. lbs.

This page consists of basic marketing information that is not defined as technical data under EAR Part 772.